



55" Outdoor Double-Sided Interactive Kiosk (w/ RF Transparent LED Box)



Model: NBSDK-550PCT-305-DFW, Double-Sided

- ✓ 55" weatherproof/outdoor interactive LCD Signs
- ✓ Tamper-proof, anti-reflection, tempered glass
- ✓ Projected capacitive multi-touch interactive glass
- ✓ Compliance: UL48 Outdoor signs and UL879 Sign controller
- ✓ Remote maintenance and system health monitoring

Design

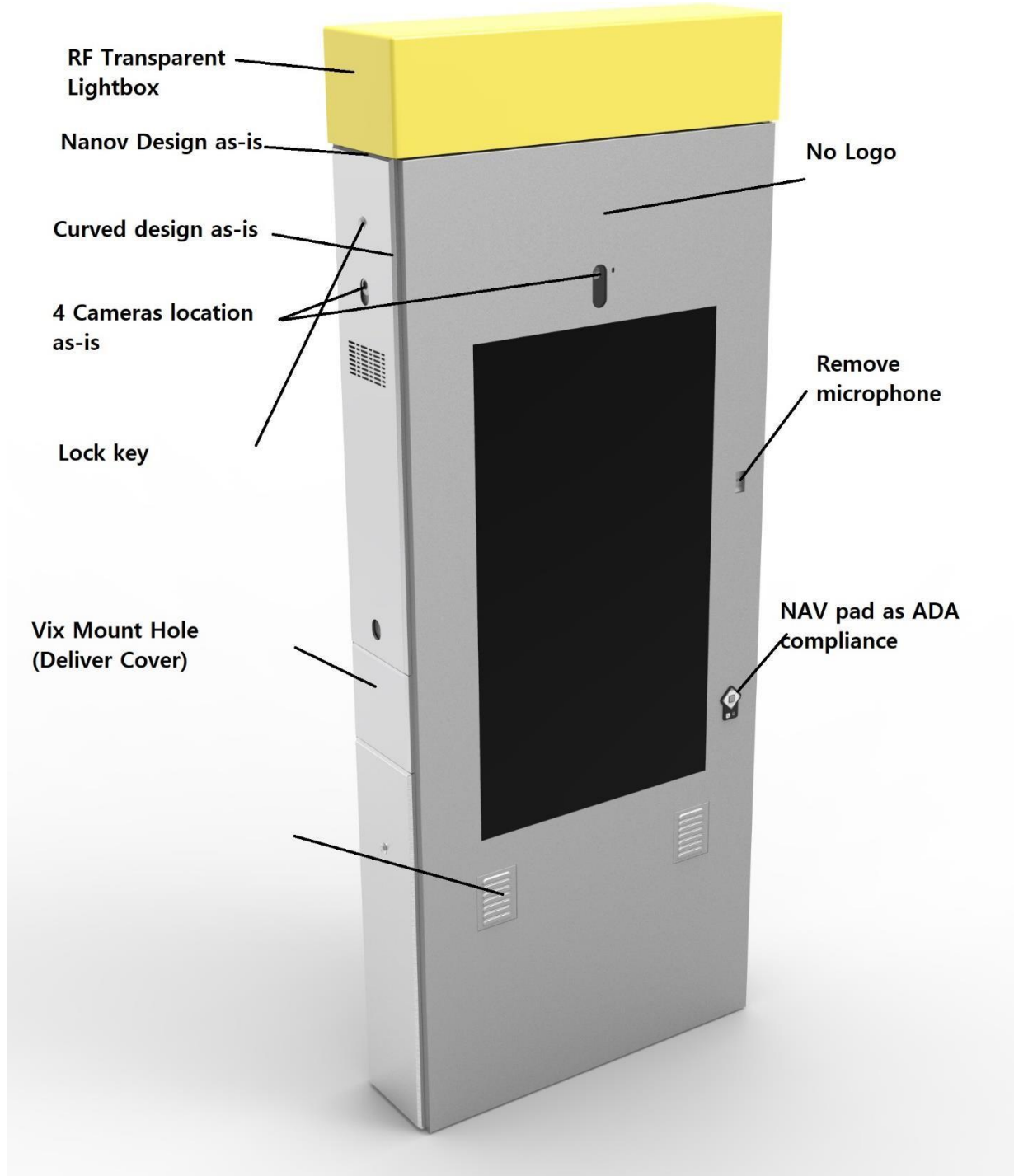

General Specifications

Parameter	Specification
Video Orientation	Portrait
Active Screen Dimensions	680mm (width) x 1210 mm (depth); (26.8 inches x 47.6 inches)
Overall Enclosure Dimension including Light Box	1044mm (width) x 2597mm (height) x 295mm (depth); (41.1 inches x 102.2 inches x 11.6 inches)
RF Transparent LED Box Dimension	1044.4mm (width) x 256mm (height) x 295.2mm (depth); (41.1 inches x 10.1 inches x 11.6 inches)
Base plate wiring slot/hole	Accommodates qty. 2, Two inches diameter conduits
Resolution	1080 x 1920 pixels
Color	16.7 million colors (8-bit)
Dimming	50-100% automatic dimming
Calibrated Intensity	2500 Cd/m ²
Color Temperature Modes	Warm / Medium / Cool
Refresh Rate	60 Hz
Contrast Ratio	1400:1
Viewing Angle	178 degrees (side/side) 178 degrees (up/down)
Burn Time (one static image)	30 min
On Screen Display (OSD)	English (default)
Programmable LED Light Box	Default color of all four sides shall be warm white without transition/movement RF Transparent Material

Power, Computers & Electronics

Parameter	Specification	
Power Consumption	1300 W (Average); 1500 W (Maximum)	
Embedded computer	CPU	Intel I7-8650u
	RAM	16GB DDR4
	Storage	512 GB SSD
	OS	Ubuntu 16.04 LTS
Inputs / Outputs	1) HDMI, DVI (720p/1080i/1080p) 2) Video compatible (USB 3.0 or similar) USB cables from Selfie cameras to computers 3) PC input via 15 pin Sub 4) LAN (RJ45, Cat 6), RS-232C 5) Serial cable between top light controller and computer	
Single dedicated receptacle power outlet	20A rated	

System Level Design & Durability

Parameter	Specification
Rated Operating Conditions	Temperature: -30°C to +45°C Humidity: 20% to 80%
Heating, Ventilation & Air Circulation (HVAC)	Automated system for heating & cooling with active air inflow & exhaust <i>[patent pending]</i>
External Housing Material	Fully-sealed, weather-proof enclosure Powder coated surface treatment
Enclosure sealing / weather proofing	Enclosures shall comply with UL 48 including outdoor rain test
Touch Screen Glass	Anti-glare, 1% max haze, anti-vandal, tempered glass.
Certification	FCC, UL Standards48, UL879 Sign Controller
Warranty	36 Months, Depot parts and labor
Mean Time Between Failure	50,000 hours

Detailed Specifications

Parameter	Specification
Sealing around kiosk penetrations, windows and ventilation fans	Sealing around kiosk penetrations, windows and ventilation fans
Programming of Top Light Controller	Controller shall be programmable through serial port
Door latches and camera windows	Shall include stainless steel screws and nuts
Wiring	UL certified Power Supplies UL Code Rated Wiring Plan CAT6a LAN Communication Cable
Touch Screen Interactivity and Integration Requirement	<ul style="list-style-type: none"> a) Projected Capacitive (PCAP), multi-touch with 2point zoom, model # ZXY100-128 b) High positional accuracy (2.5mm typical) c) 92% - 100% light transmission through PCAP d) Less than 10 ms response time e) Controller shall be grounded to enclosure f) Touch screen glass requires a minimum of 5 mm clearance from edge of glass to any metal surface g) Minimum distance between front of touchscreen and back of door shall be 3 mm h) Zytronic touch screen controller shall have a protective cover to protect bare PCB
Ambient Light Sensor	<ul style="list-style-type: none"> 1) Sensor shall be positioned in same location as cameras above the monitors 2) Default setting of ambient light sensor shall be adjusted to minimum of one hour

Physical Dimensions

Power: 1500 W

Weight: 551.16 lbs (250 kg)

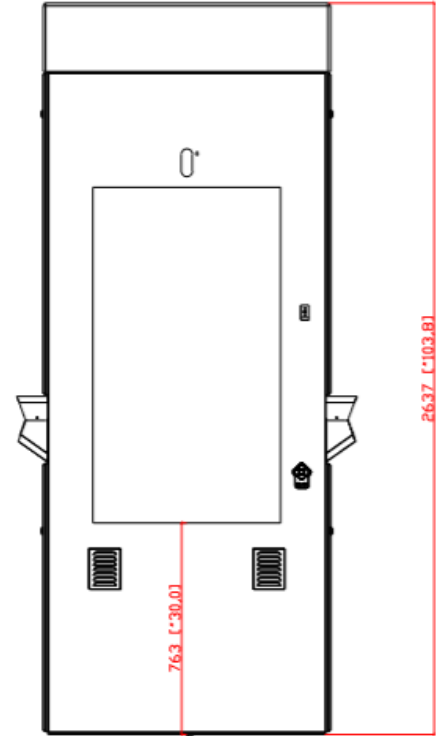
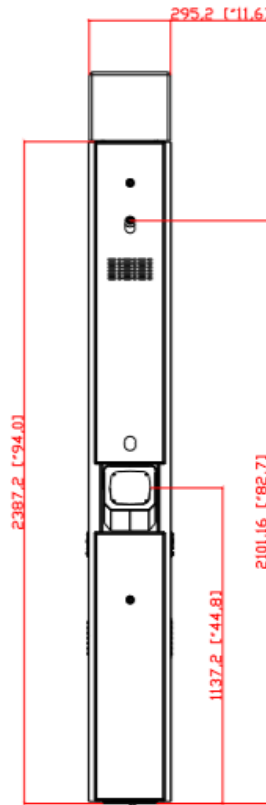
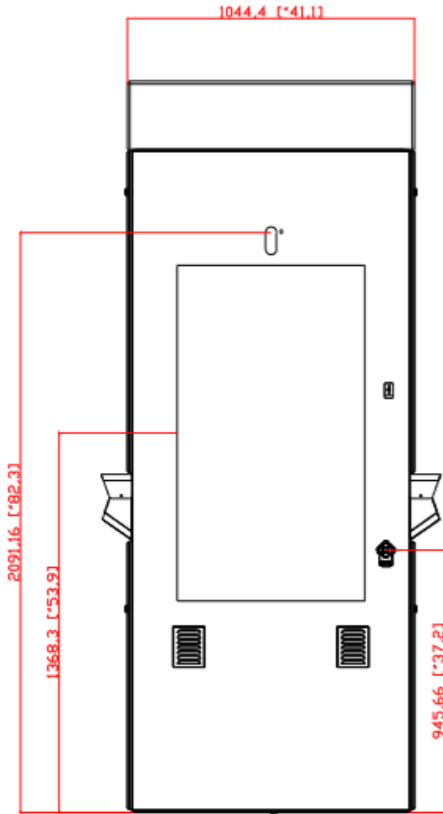
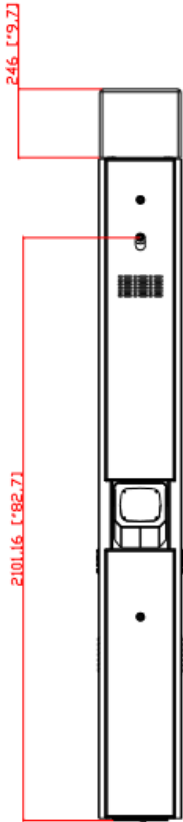

Materials

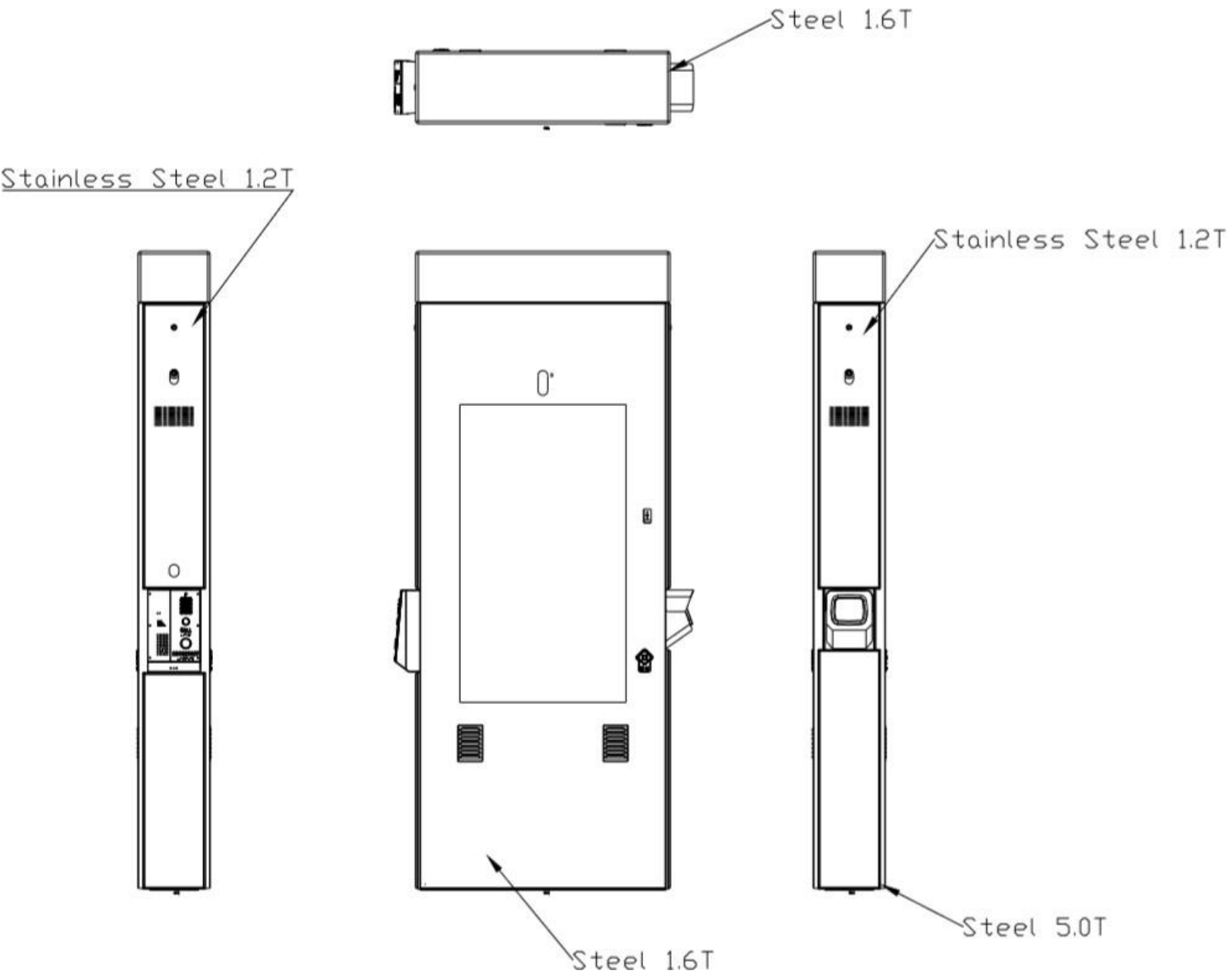

Components Layout Drawing

Side A

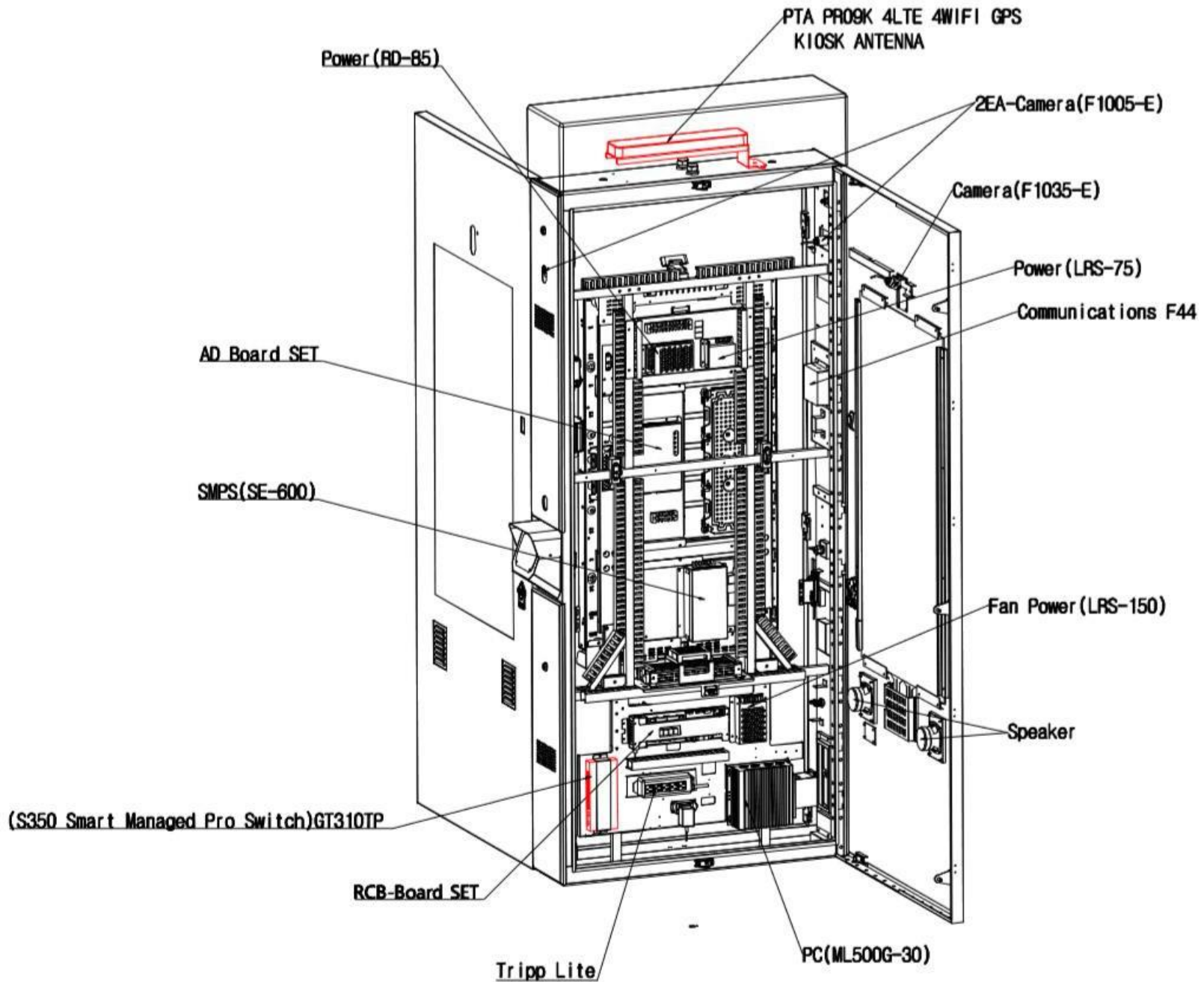

Side B

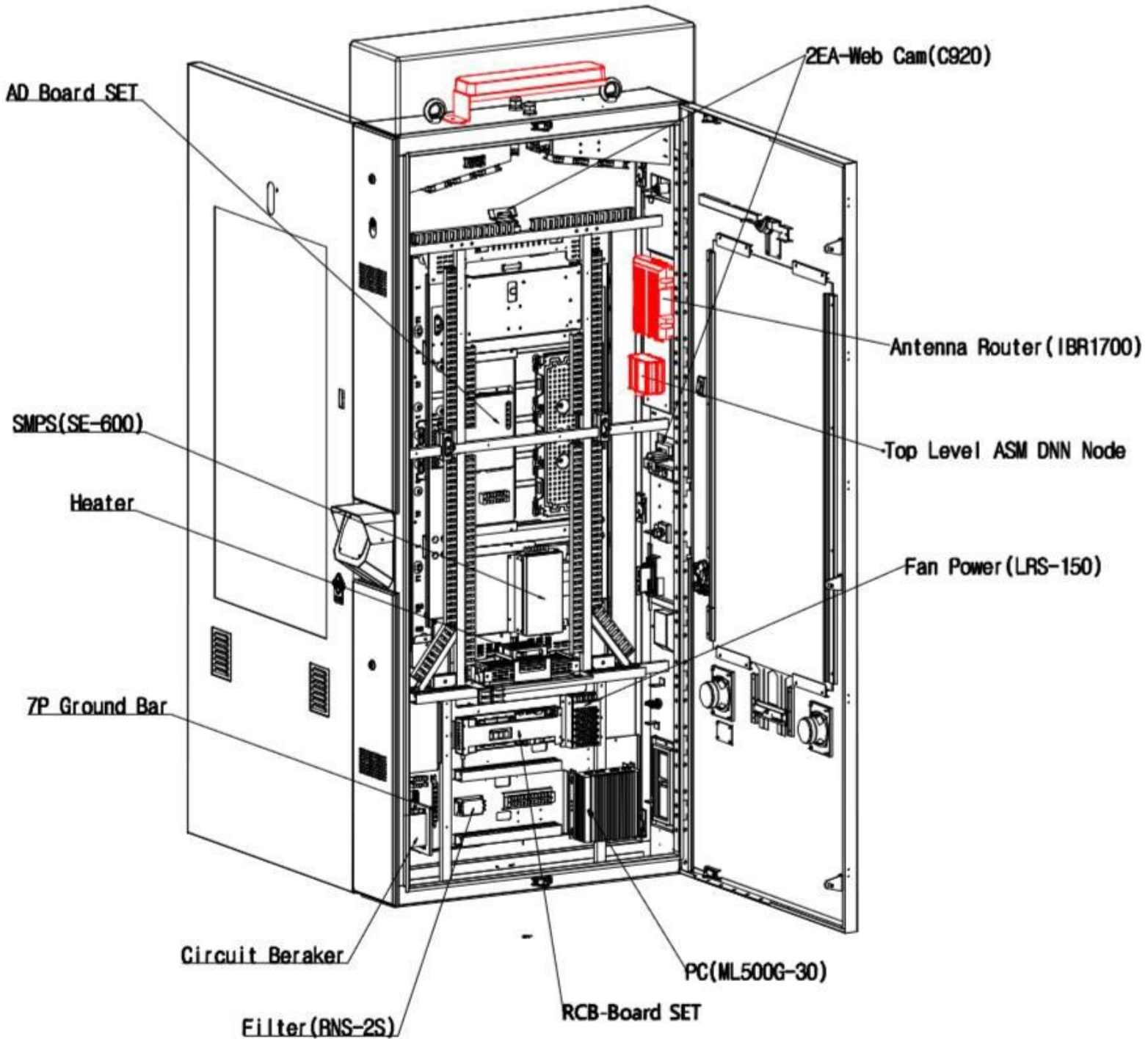

K9 Pro Integration

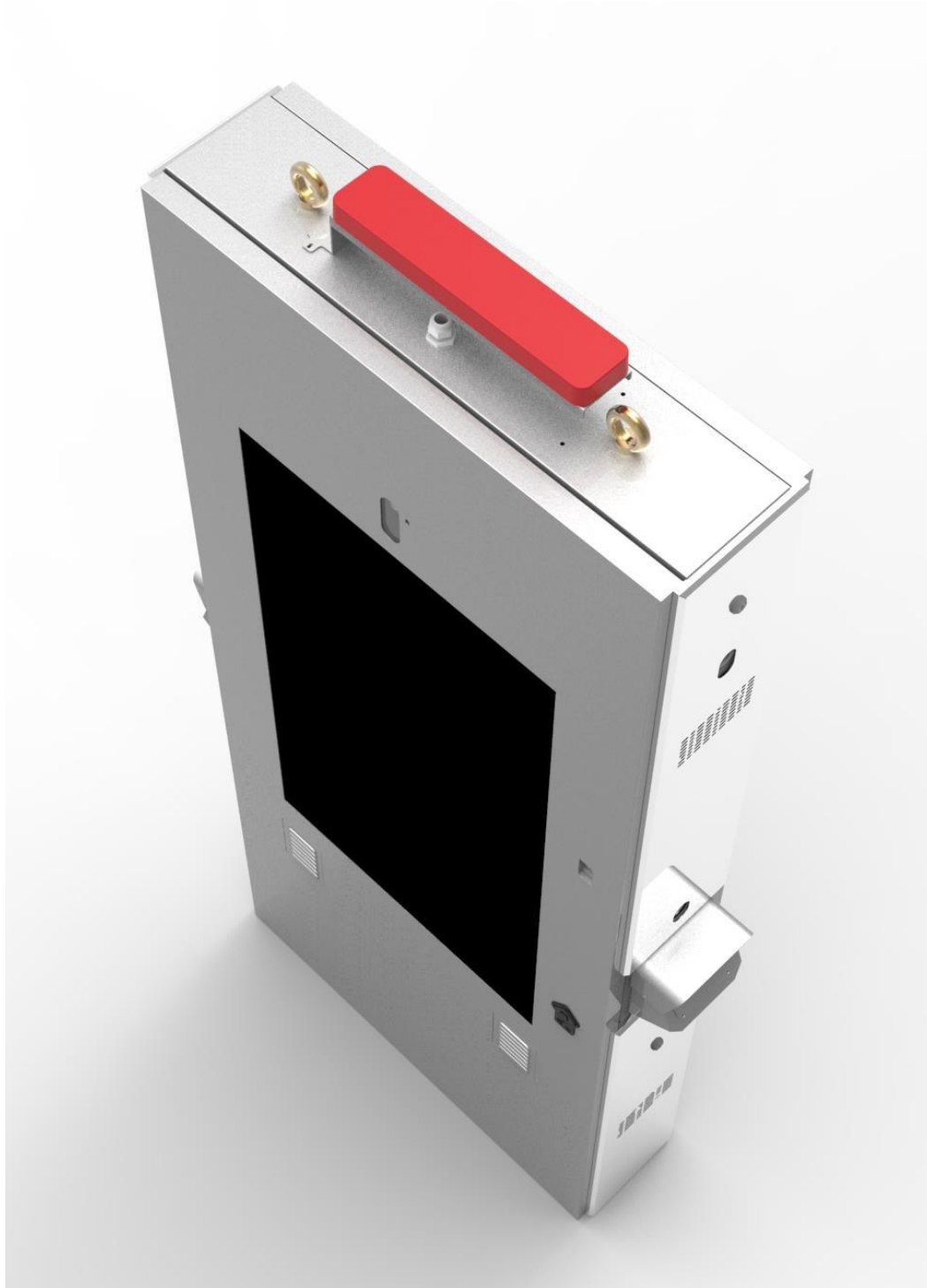

Parsec K9 – Pro Series Antenna Specification

Model PTA PRO9K 4LTE 4WiFi GPS

Product Description

Parsec's K-9 series PTA PRO9K 4LTE 4WIFI GPS is a low height nine-in-one double MIMO LTE, double MIMO Wi-Fi, and GNSS external waterproof antenna. The PTA PRO9K 4LTE 4WIFI GPS supports either the simultaneous operation of two separate LTE modems or 4x4 MIMO. This rugged low-profile omni-directional antenna works on all of the common North American LTE bands with high efficiency. Also supports CBRS and LAA. The antenna requires a single 1.5 inch mounting hole to be placed on the top of the kiosk RF Transparent Lightbox.

Features:

- LTE frequency range: 617 – 894 MHz
1710 – 2700 MHz
3400 – 3800 MHz
5150 – 5925 MHz
- Wi-Fi frequency range: 2400 – 2483.5 MHz
4900 – 5900 MHz
- Double MIMO LTE
- High Isolation
- High Efficiency: 70%
- Low Height

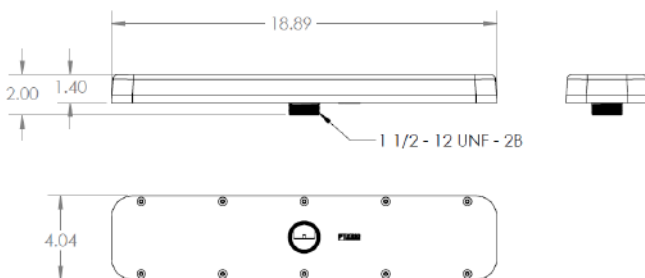

Figure 2. Product Dimensions



Managed Pro Kiosk Switch Specification

Model GS310TP

Features

- Conforms to IEEE 802.3, 802.3u and 802.3ab Ethernet Standards
- 2 Ports Dedicated SFP Fiber Ports
- 8 ports auto-negotiation 10/100/1000Mbps Ethernet RJ-45 ports
- Automatic MDI/MDIX crossover for each RJ-45 port
- Backpressure for Half-duplex mode and Flow control for Full-duplex mode
- Store-and-forward switching architecture
- 4K entry MAC address table and automatic address learning
- Jumbo Frame support (9KByte)
- L2/L3/L4 Access Control Lists
- QoS (Quality of Service) for traffic prioritization including port based, 802.1p and L2/L3/L4 DSCP-based
- Performs non-blocking full wire speed
- Snmp V1, V2c, V3 and RMON
- LED-indicator for Power, LNK/ACT



[Click to open NetGear GS310TP datasheet](#)

Model GS310TP

Model Name	GS310TP
Form-Factor	Desktop
Hardware at Glance	
Parameter	Description
10/100/1000 Base-T RJ45 ports	8 ports
1000BASE-X Fiber SFP Ports	2 ports
PoE+802.3at Ports (Budget)	8 PoE+ (55W)
Power Supply	1 external PSU, DC 54V 1.25A
Fans	Fan-less
Software at Glance: Layer 2 Features	
Parameter	Description
Management	Web Browser-based GUI (HTTP/HTTPS), PC-Based Smart Control Center Utility (SCC) RMON, SNMP
IPv4 ACL and QoS	L2, L3, L4, ingress
IPv4 Multicast Filtering	IGMP Snooping, Querier, Fast Leave, L2 Multicast Router
Auto-VOIP/Auto Video	Yes
IEEE(802.3az) Energy Efficient Ethernet	Yes
MAC VLANs	8K or 16K Max MAC 64 VLANs Static, Dynamic, Voice
Convergence Advanced Features	LLDP-MED RADIUS 802.1X LACP, STP, SNMP

Environmental Characteristics	
Storage	-20°C ~ 70°C
Humidity	10% to 90%
Size	236 x 101 x 30mm
Power Full Load	69.3 W
Heat Dissipation (Max)	236.59 BTU/hr

Hardware Features	Benefits
Dedicated SFP Fiber Uplinks	Dedicated SFP ports provides fiber uplinks without sacrificing any downlink Gigabit port. Up to 4 SFP ports provide not only redundant uplinks, but can also build dual redundancy by a trunked uplink with link aggregation and failover, the dual-redundancy, a powerful design for the network virtualization
PoE + Support on all ports (GS310TP and GS324TP)	Flexible to plug-in or change into high-power PD devices on any port without worrying which one port to plug in and whether it will be running out of PoE+ ports.
Low Acoustics	Fan-less design on GS308T/GS310TP/GS324T, and maximum acoustic noise level at 32.8dB for GS324TP and 26dB for GS348T respectively at 25°C (77°F) ambient for quieter office environment
L2 Software Features	Benefits
Advanced per port PoE controls	Remote power management of PoE connected devices including operation scheduling (e.g. Wireless APs, IP security cameras, secure access door locks, IoT devices...)
ACL filtering to permit or deny traffic based on	Provide granular network access control including L2/L3/L4 access control lists (ACLs).
Robust security features: <ul style="list-style-type: none"> • 802.1x authentication (EAP) • Port-based security by locked MAC • DHCP Snooping 	Build a secured, converged network with all types of traffic by preventing external attacks and blocking malware, while allowing secure access for authorized users with RADIUS 802.1x port authentication.
Comprehensive QoS features: <ul style="list-style-type: none"> • Port-based or 802.1p-based prioritization • Layer 3-based (DSCP) prioritization • Port-based ingress and egress rate limiting 	Advanced controls for optimized network performance and better delivery of mission-critical traffic such as voice and video.
Auto-VoIP, Auto-Voice VLAN, and Auto-Video VLAN	Automatic Voice over IP prioritization (Auto-VoIP) simplifies most complex multi-vendor IP telephone deployments either based on protocols (SIP) or on OUI bytes (default database and user-based OUIs) in the phone source MAC address, providing the best class of service to VoIP streams (both data and signaling) over other ordinary traffic by classifying traffic, and enabling correct egress queue configuration. Similarly, Auto-Video

	VLAN enables IGMP snooping to minimize broadcast streams.
IGMP Snooping	Facilitate fast receiver joins and leaves for multicast streams. Save cost and improve network efficiency by ensuring multicast traffic only reaches designated receivers without the need of an extra multicast router
Protected Ports	Ensure no exchange of unicast, broadcast, or multicast traffic between the protected ports on the switch, thereby improving the security of your converged network. This allows your sensitive phone conversations to stay private and your surveillance video clips can be forwarded to their designated storage device without leakage or alteration.
DHCP Snooping	Ensure IP address allocation integrity by only allowing DHCP messages from trusted DHCP servers and dropping malformed DHCP messages with a port or MAC address mismatch.
Dynamic VLAN Assignment (RADIUS)	IP phones and PCs can authenticate on the same port but under different VLAN assignment policies. Users are free to move around and enjoy the same level of network access regardless of their physical location on the network.
Dual Firmware Images	Dual firmware images for transparent firmware updates with minimum service interruption.

Video Ai Node Specification, Model DNN Node™

Parameter	Specification
Communications	Wifi 802.11AC, Bluetooth, CANbus, 2x USB3.0, Gb Ethernet, 2 Uarts, SPI, I2C (Ethernet is the only communication brought outside of the enclosure by default, but others can also be exposed upon request.)
Storage	32GB onboard flash + MicroSD expandable storage + M.2 SSD (NVMe)
Power	PoE+ (30W)
Dimensions	Approximately 2.5" x 2.5" x 5"
Environmental	IP67 case rating, operating temp range -20°F to 140°F
Passive Cooling	No cooling fans to get fouled or damaged



Validator Specification

Model: VIX CR600

General Specifications:	
Type	Descriptions
Configuration	400MHz ARM9 One ISO 7816 compliant SAM socket, 128MB RAM able to communicate at up to 625Kbps 128MB Flash Supports Linux 2.6.31 or newer
Compliance	Vix supplies products to meet many local and globally recognized standards such as CE, RoHS, various smartcard standards and many others. For more details on how Vix can meets your local requirements please contact Vix directly.
Panel, Gate and Desktop Configurations:	
Type	Descriptions
Compliance	Certified to EMV2.0.1
Dimensions	Panel: 148mm x 128mm x 38mm, Desktop: 141mm x 107mm x 32mm
User Interface	Colour TFT LCD (3.5" 1/4VGA) RGB LED ring around the display for user feedback Audio feedback >=72dBA at 1m
Antenna	Card reader antenna extends around the circumference of the unit, providing maximum target for reading cards
Physical Features	Can be used on a desktop and also panel or wall mounted
Features	10/100Mbps Ethernet Digital audio-driven speaker Diagnostics port with RS232 1 x High Speed USB2.0 Host or Device RS422 serial connection - at up to 460kbps 1 x Full Speed USB2.0 Host Support for wide input voltages - min 9-38v Battery-backed real time clock

Antenna:	
Type	Descriptions
Configuration	EMV level 1 capable
Dimensions	104mm(w) x 67mm (d) x 20mm (h)
Antenna	Ferrite-backed antenna included for maximum read range
Physical Features	Suitable for integrating into kiosks, vending machines, or any equipment requiring contactless payment capability
TP5 Upgrade Kit:	
Physical Features	Mount kit for conversion of Vix TP5000 and TP5700 ticketing machines for AFC integration with EMV payments



Concept Drawing NBSDK-550PCT-305-DFW (No validator)

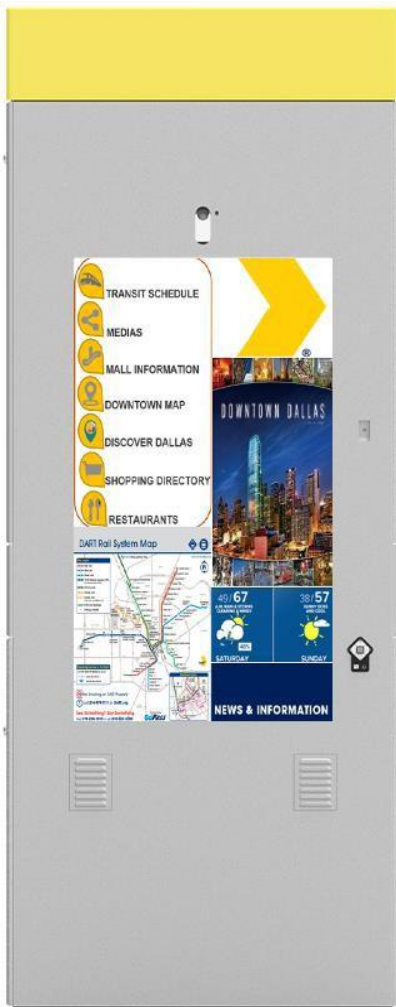

Concept Drawing NBSDK-550PCT-305-DWF (One validator)



Concept Drawing NBSDK-550PCT-305-DWF (Two validators)



Modem Specification

Cradlepoint Model COR IBR1700

Parameter	Specification
Model	MA1-17001200-NNA
LTE	Embedded 600 Mbps or 1 Gbps* LTE Advanced Pro modem & DC-HSPA+ fallback
WIFI	Simultaneous Tri Band 802.11 a/b/g/n/ac Wave 2 MU-MIMO
Material	Metal
Ignition Sensing	Automatic ON & time-delay OFF
OBDII Support	Yes, with accessory cable
Input Range	9-33 VDC (and low voltage shutoff)
Weight	3 lb. 7 oz (1.7 kg)
Support	Phone support: 24-hour weekdays with emergency response on weekends, Web: 24x7, Chat: 24x5
Cloud Managed	Yes, with NetCloud Manager
Carriers / Operators	AT&T, Verizon, T-Mobile, Sprint, Canada (Bell, Rogers, TELUS), Europe, Australia/New Zealand***
Ethernet Ports	5 LAN/WAN switchable 10/100/1000
Ruggedized	Yes, IP64, Shock/Vib/Humidity MIL Spec 810G & SAE J1455
GPS / GNSS	Yes, with active antenna & dead reckoning (GNSS/GPS + 3D Accel. + OBD-II)
Operating Temperature	-30 °C to 70 °C (-22 °F to 158 °F)
Size	8.8 × 7.5 × 1.7 in (224.3 × 190 × 44 mm)

Fallover	Yes
Dual Modem Capable	Yes, field-upgradable MC400 modem slot



Speaker Specification, Model NICS-100825

Impedance	8 Ohms	
Power	Nominal	25 Watts
	Maximum	50 Watts
General Specifications:		
Type	Descriptions	
Nominal Diameter	100 mm (4 inches)	
SPL	86 dB /W/M	
Frequency Range	FO - 13000 Hz	
Voice Coil Diameter	24.45 mm (1 inch)	
Voice Coil Material	Copper	
Magnet Weight	0.28 Kg (10 oz.)	
Piston Diameter	83 mm (2.9 inches)	
Magnet Gap Depth	4 mm (0.14 inches)	
Voice Winding Depth	10 mm (0.35 inches)	
Thiele/Small Parameter:		
Type	Descriptions	
DC resistance	6.2 Ohm	
Fs	79.9 Hz	
Qts	0.432	
Qes	0.532	

Qms	2.283
Vas	3.4 L (0.12ft3)
Sd	0.0031 m2 (4.8 inch2)
Xmas	2.75 mm (0.10 inches)
Vd	8.525 ccm
Half-Space Reference Efficiency	0.13%
Efficient Bandwidth	94.7 Hz
Le	0.32 mH
Cms	0.00097 m/N
BL	3.1 N/A
Rms	0.96 Kg/s
Mounting Information:	
Type	Descriptions
Overall Diameter	106 mm (4.1 inches)
Bolt Circle Diameter	116 mm (4.5 inches)
Baffle Cutout Diameter	102 mm (4.0 inches)
Depth	55 mm (2.1 inches)
Net Weight	0.74 Kg (1.63 lb.)

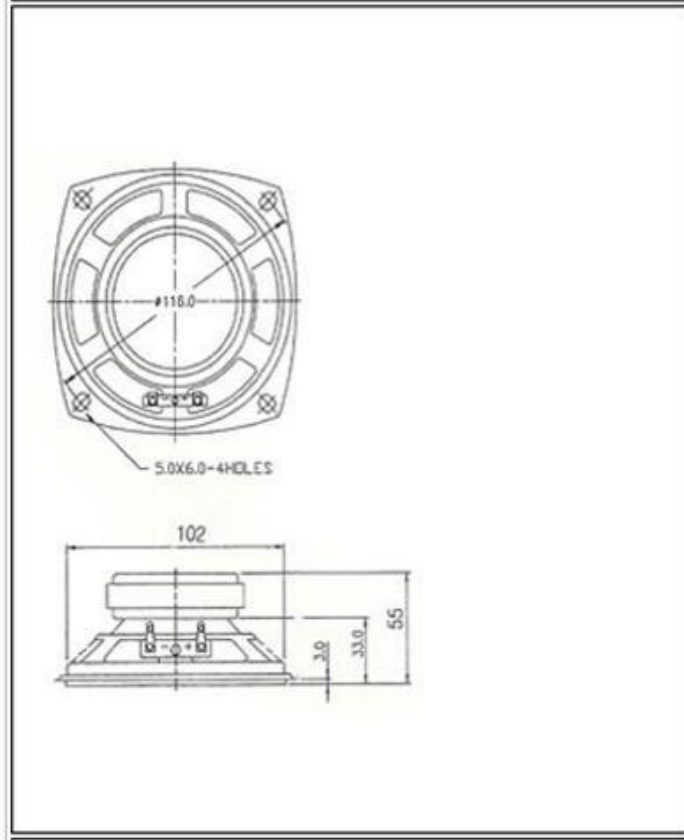

LED Lighting Box Specification

Model NIG563ZEGBW

Features

- ROHS and PB free
- I.C compatible
- EIA STD package
- Compatible with automatic placement equipment
- Compatible with infrared reflow solder process
- Preconditioning: accelerate to JEDEC level 3

Parameter	Symbol	LTST-G563ZEGBW				Test Condition	Unit
			Red	Green	Blue		
Luminous Intensity	IV	Min.	500	1400	240	I _F = 20mA	mcd
		Typ.	-	-	-		
		Max.	1000	2200	480		
Viewing Angle	2θ _{1/2}	Typ.	120			I _F = 20mA	deg
Peak Emission Wavelength	λ _p	Typ.	630	523	458		nm
Dominant Wavelength	λ _d	Min.	619	520	460	I _F = 20mA	nm
		Typ.	-	-	-		
		Max.	628	530	470		
Forward Voltage	V _f	Min.	1.9	2.9	2.9	I _F = 20mA	V
		Typ.	-	-	-		
		Max.	2.4	3.4	3.4		
Spectral Line Half-Width	Δλ	Typ.	15	25	20	I _F = 20mA	nm
Reverse Voltage	VF _z	Min.		-	-	IF _z = 10mA	V
		Typ.		6.5	6.5		
		Max.		-	-		

Luminous Intensity Color: <u>Red</u> , Unit: mcd @ 20mA		
Bin Code	Min.	Max.
1R	500.0	700.0
2R	700.0	1000.0

Tolerance on each Intensity bin is +/-15%

Luminous Intensity Color: <u>Green</u> , Unit: mcd @ 20mA		
Bin Code	Min.	Max.
1G	1400.0	1800.0
2G	1800.0	2200.0

Tolerance on each Intensity bin is +/-15%

Luminous Intensity Color: <u>Blue</u> , Unit: mcd @ 20mA		
Bin Code	Min.	Max.
0B	1400.0	1800.0

Tolerance on each Intensity bin is +/-15%

Recommended Soldering Conditions

Reflow soldering		Soldering iron	
Pre-heat	150 ~ 200°C	Temperature	300°C Max.
Pre-heat time	120 sec. Max.	Soldering Time	3 sec. Max. (one time only)
Peak Temperature	260°C Max.		
Soldering Time	10 sec. Max. (Max. two times)		

Nanov Display Inc.

Building 77, Navy Yard
141 Flushing Ave Unit 705
Brooklyn, NY 11205

Tel: +1-877-409-8844, Fax: +1-866-431-7242

info@nanovdisplay.com

Copyright All Rights Reserved Nanov Display Inc.