



55" Outdoor Double-sided LCD Banner



Model: NISDB-550P-135-DFW, Double-Sided LCD Banner

- ✓ 55" double-sided weatherproof/outdoor LCD signs, portrait mode
- ✓ Fully sealed, IP65, sunlight readable
- ✓ Vandal-proof, 5mm anti-reflection, tempered glass
- ✓ Embedded computer – Intel i-5 processor, Windows 10
- ✓ Remote maintenance and system health monitoring

General Specifications

| Parameter | Specification |
|------------------------------|---|
| Video Orientation | Portrait |
| Overall Physical Dimensions | 777mm (width) x 1307mm (height) x 300mm (depth); (30.6 inches x 51.5 inches x 11.8 inches) |
| Overall Screen Dimensions | 675mm (width) x 1266mm (height) (26.6 inches x 49.9 inches) |
| Resolution | 1080 x 1920 pixels |
| Color | 16.7 million colors (8-bit) |
| Dimming | 50-100% automatic dimming |
| Calibrated Intensity | 2500 Cd/m ² |
| Calibration | At factory or via rs232c |
| Color Temperature Modes | Warm / Medium / Cool |
| Refresh Rate | 60 Hz |
| Contrast Ratio | 1400:1 |
| Viewing Angle | 178 degrees (side/side) 178 degrees (up/down) |
| Burn Time (one static image) | 30 min |
| On Screen Display (OSD) | English (default) |

Power, Computers & Electronics

| Parameter | Specification | |
|--|--|--|
| Power Consumption | 550 W (Average); 800 W (Maximum) | |
| Option: Embedded computer | CPU | Intel Core i5 processor |
| | RAM | DDR3 3GB |
| | Storage | SSD 64GB |
| | Dimensions (W x H x D) | 150mm x 150mm x 50mm; (5.9inches x 5.9inches x 2.0inches) |
| | OS | Windows 10 Home |
| Inputs / Outputs | 1) PC Input via 15 - Pin Sub "D" 1 2) HDMI, Ethernet RJ45 3) DVI: 720p/1080i/1080p 4) RS-232C | |
| Single dedicated receptacle power outlet | 20A rated | |

System Level Design & Durability

| Parameter | Specification |
|---|--|
| Rated Operating Conditions | Temperature: -40°C to +50°C Humidity: 20% to 80% |
| Heating, Ventilation & Air Circulation (HVAC) | Automated system for heating & cooling with active air inflow & exhaust |
| External Housing Material | Fully-sealed, weather-proof enclosure Powder coated surface treatment |
| Enclosure sealing / weather proofing | Enclosures shall comply with UL 48 including outdoor rain test |
| Touch Screen Glass | Anti-glare, anti-vandal, 5mm tempered glass. |
| Certification | FCC |
| Warranty | 36 Months |
| Mean Time Between Failure | 50,000 hours |

Physical Dimensions

Weight per Unit: 180 kg (396 lbs)

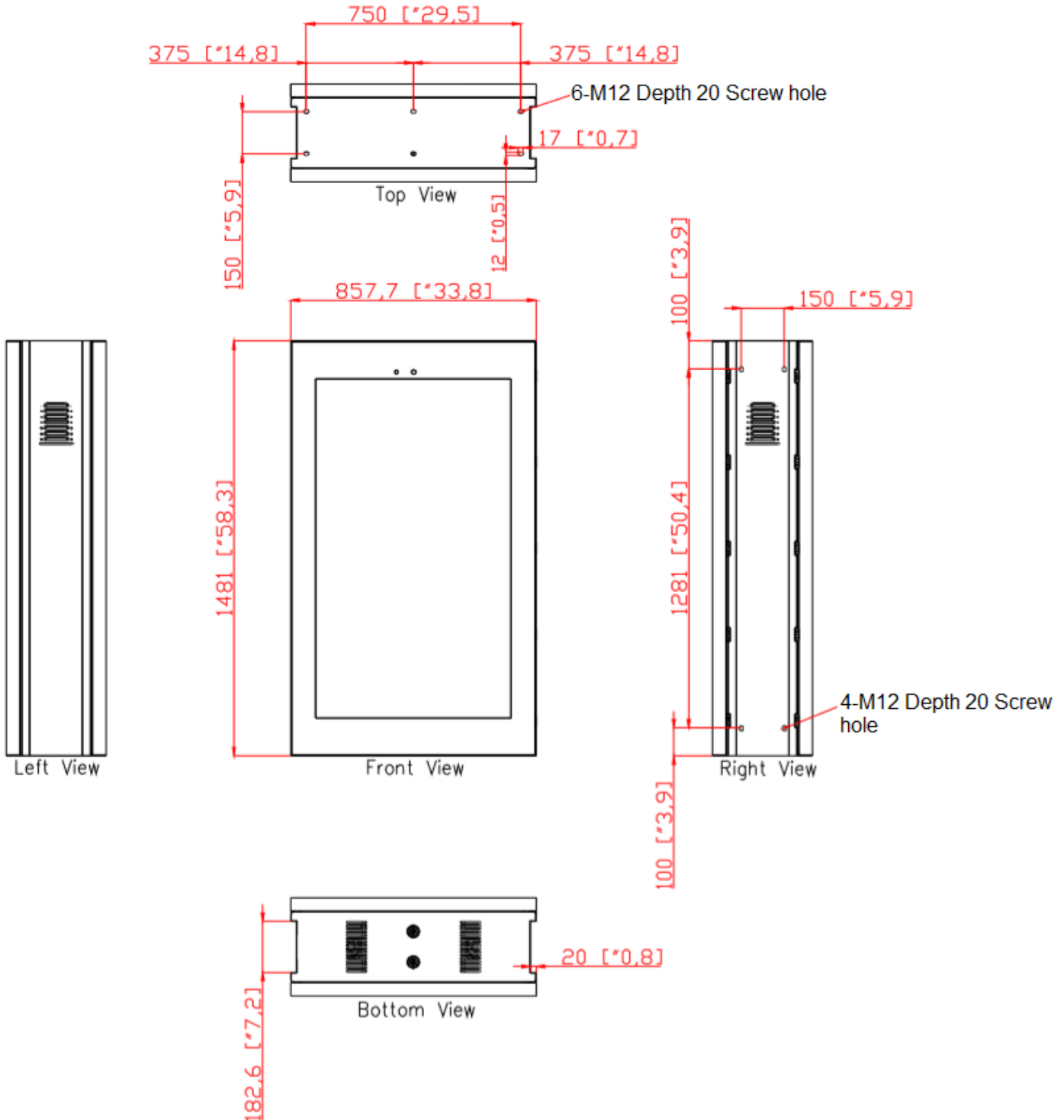

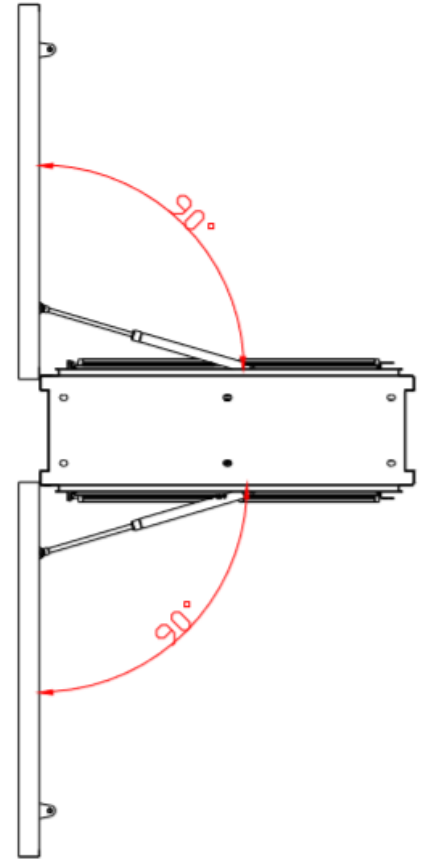
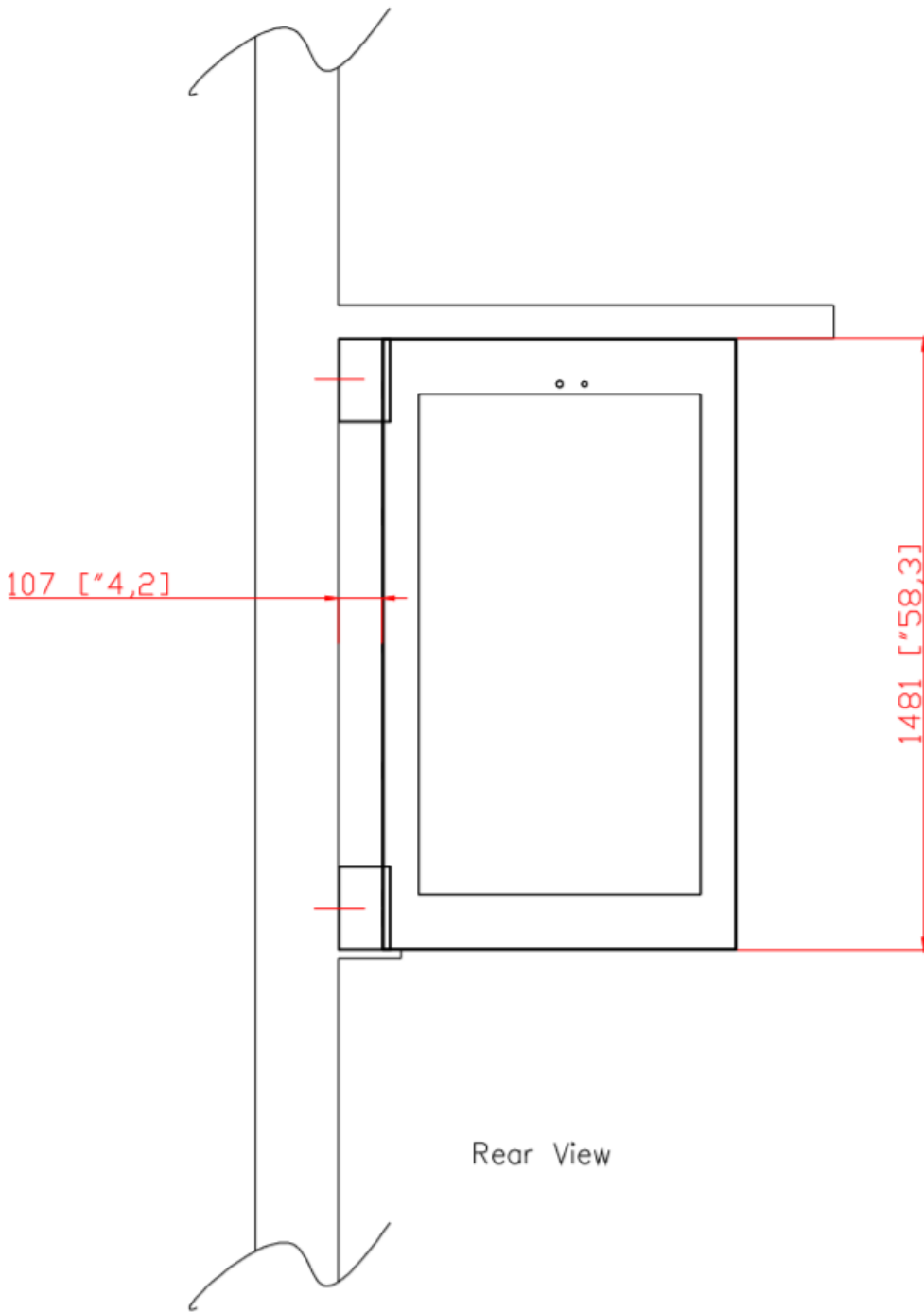

Outdoor Door Opening – Easy Maintenance & Ventilation Concept

Nanov Display products are designed with easy maintenance access in mind. You can swing open the enclosure door to access the monitor in no time at all. To access the electronics directly, the screen can be lifted thanks to its mounting with heavy-duty pneumatic springs.



Door Opening Maintenance Concept

Banner Concept Drawing

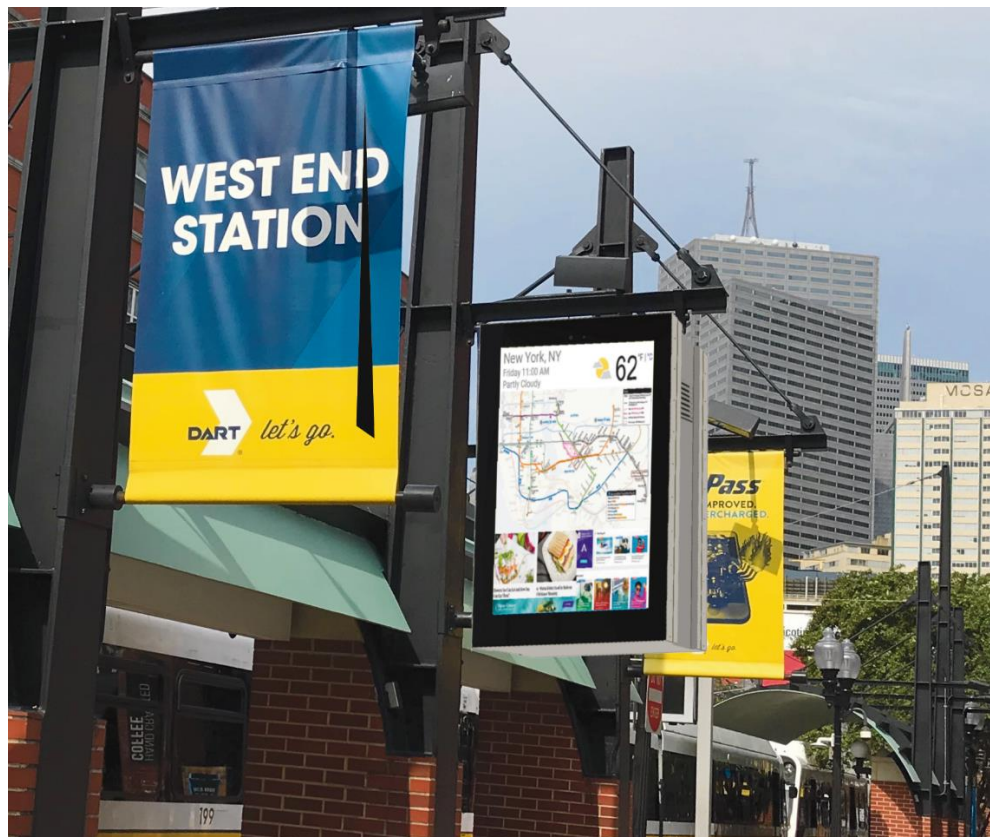

Banner Custom Bracket

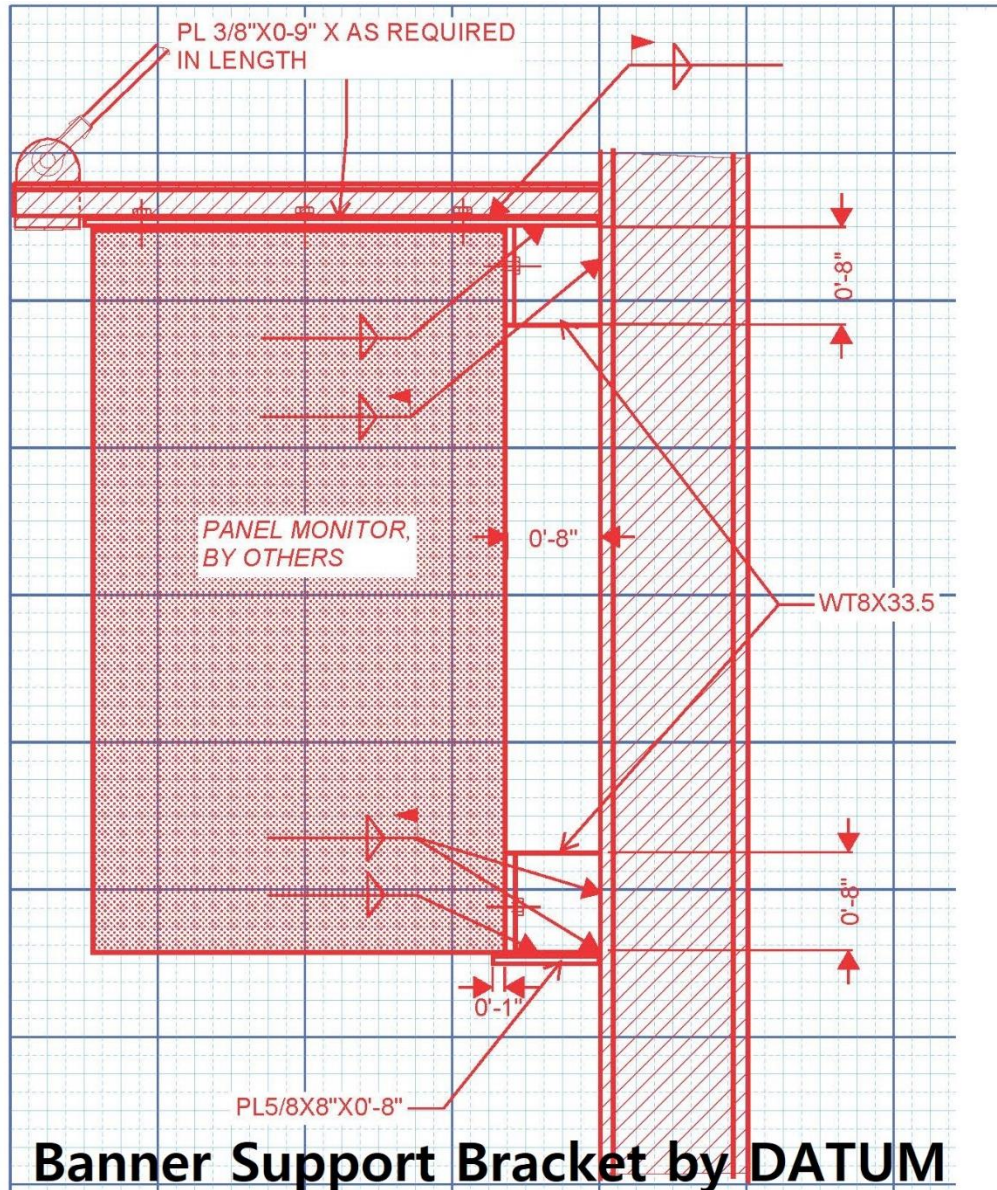

Nanov Display Inc.

141 Flushing Ave Suite 705

Brooklyn, NY 11205

Tel: +1-877-409-8844, Fax: +1-866-431-7242

info@nanovdisplay.com