

STRUCTURE AND WINDLOAD STUDY OUTDOOR TRANSIT DID (LRT STATIONS, OSLO)

Fully sealed vibration tested transit outdoor display

**Model: NIOD700P-700, 70" Portrait, double-sided 700cd, IP65
Cross Track monitor**

Excerpt

April 21, 2017



The 1st Chapter. SUMMARY OF STRUCTURE REVIEW

1.1 SITE SUMMARY

We analyze the structural safety of an 70inch advertising board installed in Oslo subway station.

1.2 STRUCTURAL REVIEW CRITERIA

Design Method	. Ultimate Strength Design Method (RC) / Allowable Stress Design (S, SRC) . Limit State Design (S, SRC)
Applied Statute	. Building Act / Building Act Enforcement Decree
Applied Rule	. Building Regulation / Regulation for Structure in Building
Applied Criteria	. Korean Building Code (KBC2016) . Korean Steel Structure Design Code (KSSC-ASD03)
Reference Criteria	. ACI 318 . AISC-ASD / AISC-LRFD / ANSI/AISC 360-05

1.3 Structure Materials Standards and Specified Strength

STEEL : KS D 3503 Rolled Steel Materials for Structure

- SS400, $F_y = 235 \text{ MPa}$

1.4 Analysis Program

- MIDAS/GEN (Frame Analysis, Design)
- MIDAS/SET (Member Design)

The 2nd Chapter. Review of Load

Dead Load(D.L) is considered automatically on analysis program, Live Load(L.L) is applied with 50 N/m, monitor load 1402N/m (1500N/1.07m=1402N/m) and Wind Load(W.L) is applied with 70 Pa offered by manufacturer. Also Horizontal Load is applied with 100 Pa to consider the load which man lean on the board.

Horizontal Load ($100\text{N/m}^2 \times 1.07\text{m}/2 = 46.7\text{N/m}$) --> Applied 50N/m in this review

It was focused on trains passing the station without stopping. During the test most of these trains passed the station at a very low speed.

Maximum pressure from the trains was measured to approx. 70 Pa.

Nearly all pressure pulses measured were negative (under pressure).

LOAD COMBINATION		
1	sLCB1	D+L
2	sLCB2	0.75(D+L+WY)
3	sLCB3	0.75(D+L-WY)
4	sLCB4	0.75(D+WY)
5	sLCB5	0.75(D-WY)

The 3rd Chapter. Structure Review

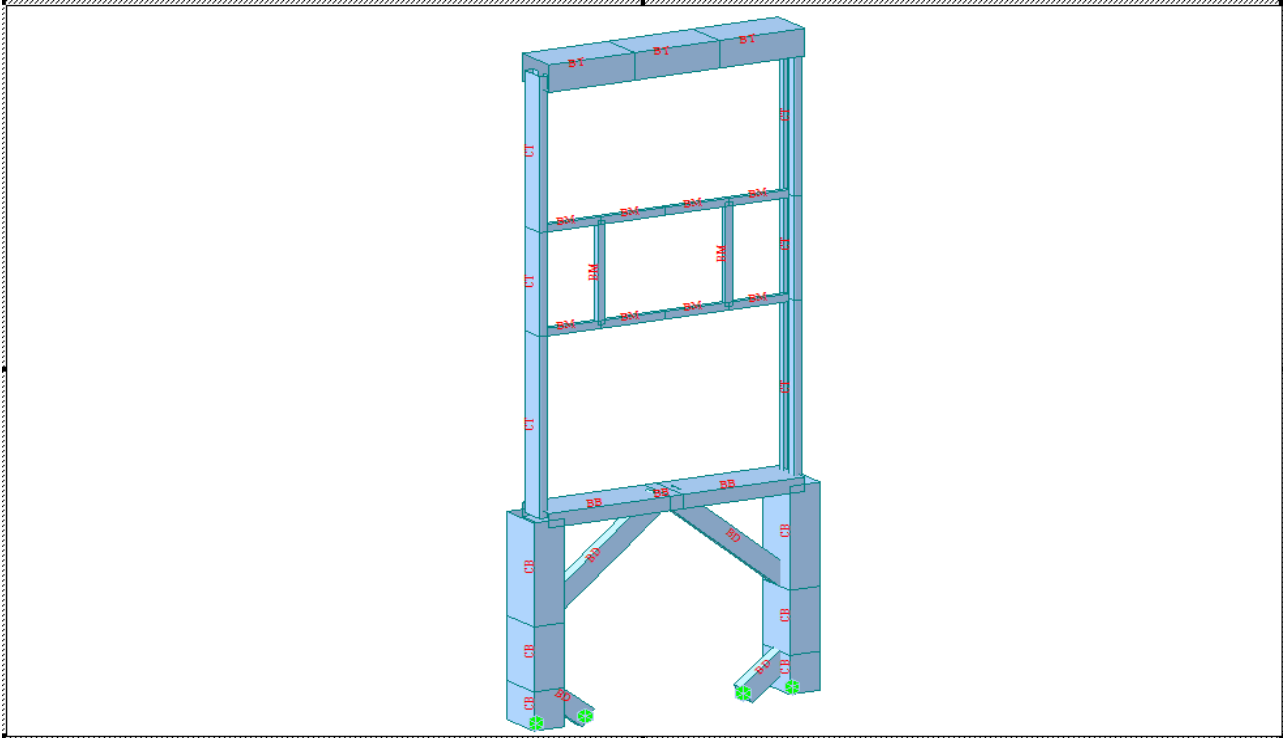

<Modeling>

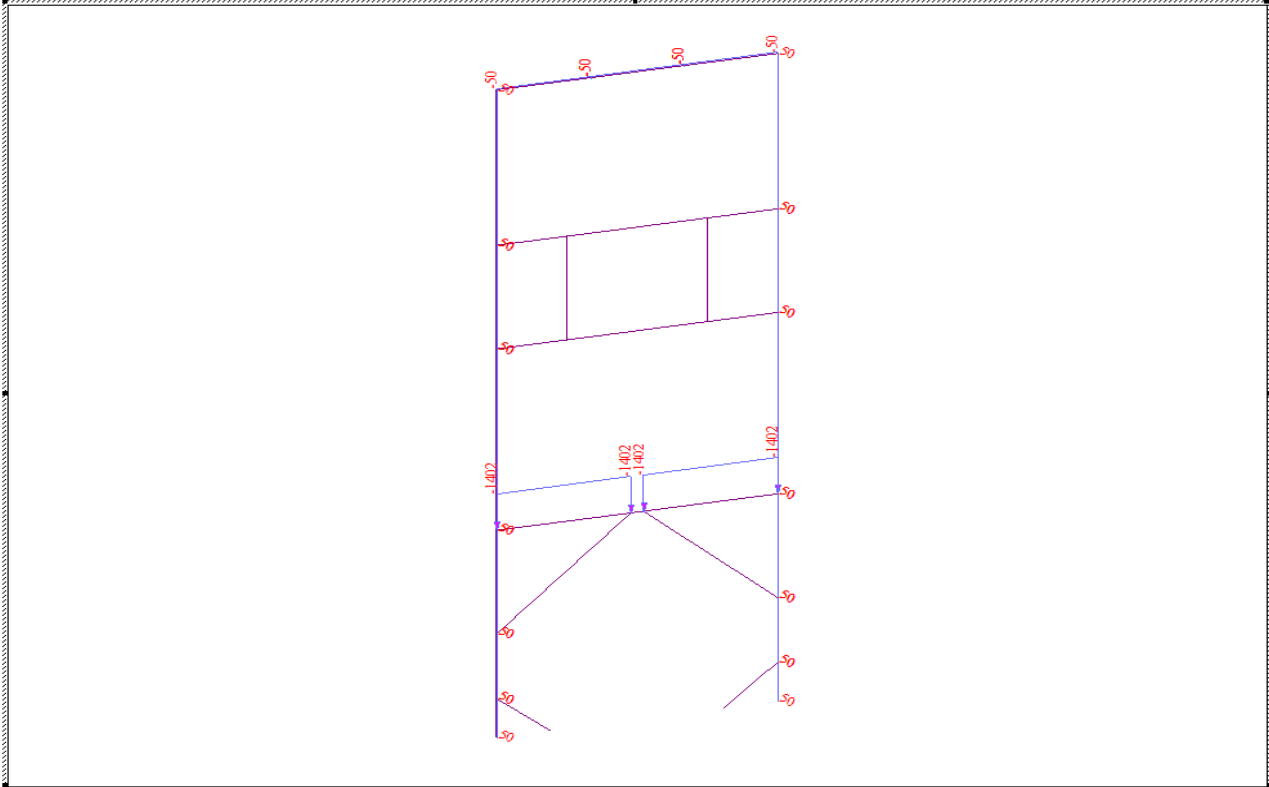

<Applied Load>

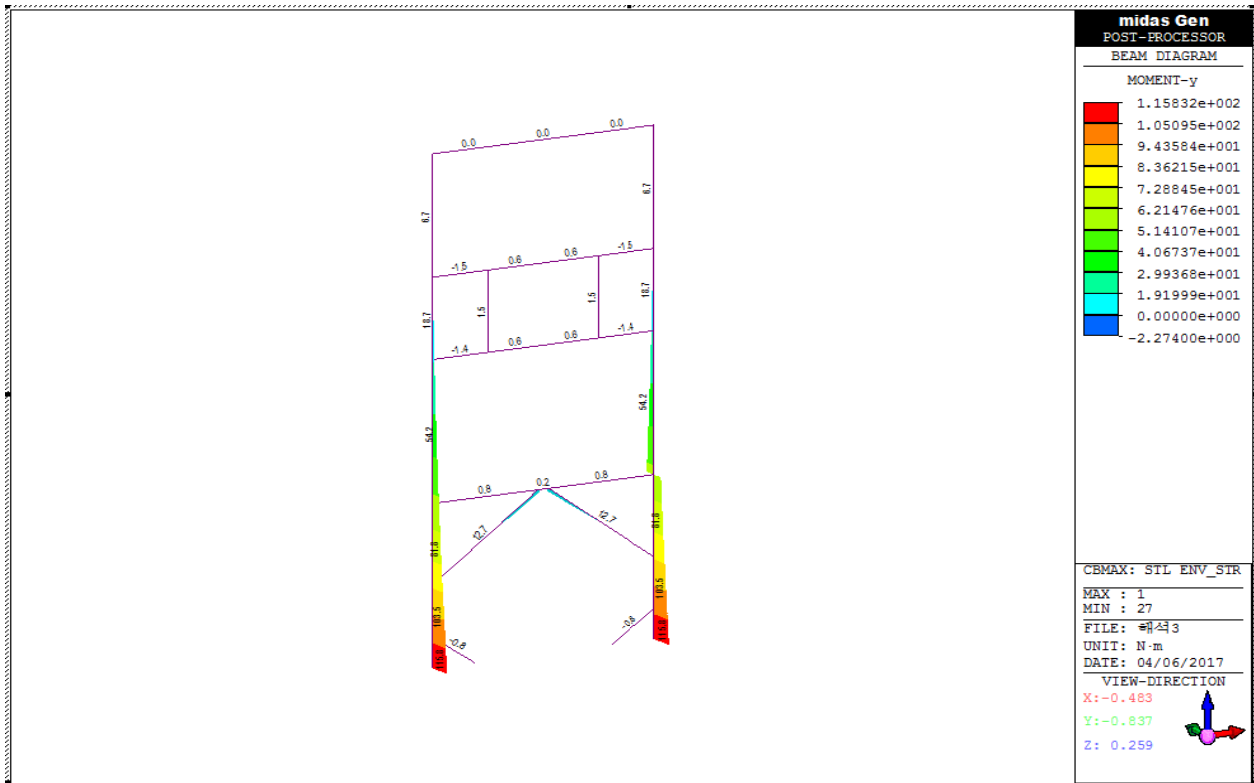

<Bending Moment Diagram>

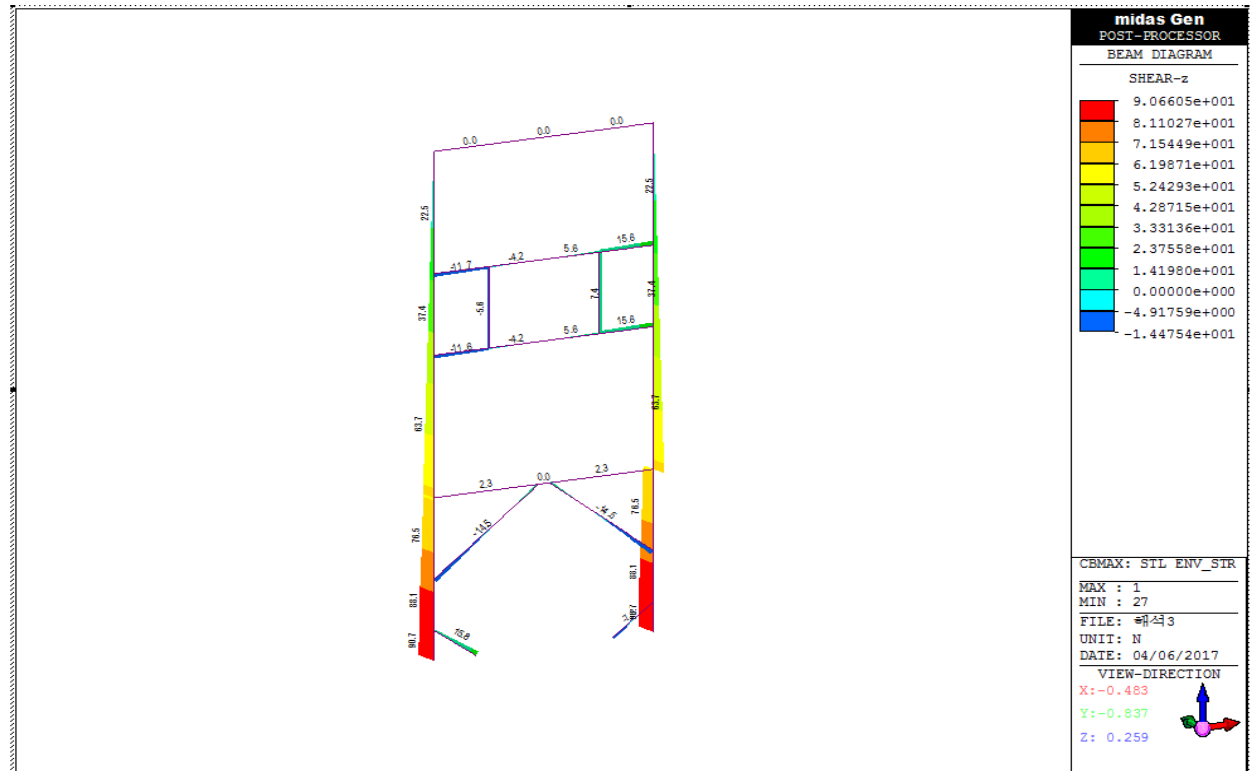

<Shear Force Diagram>

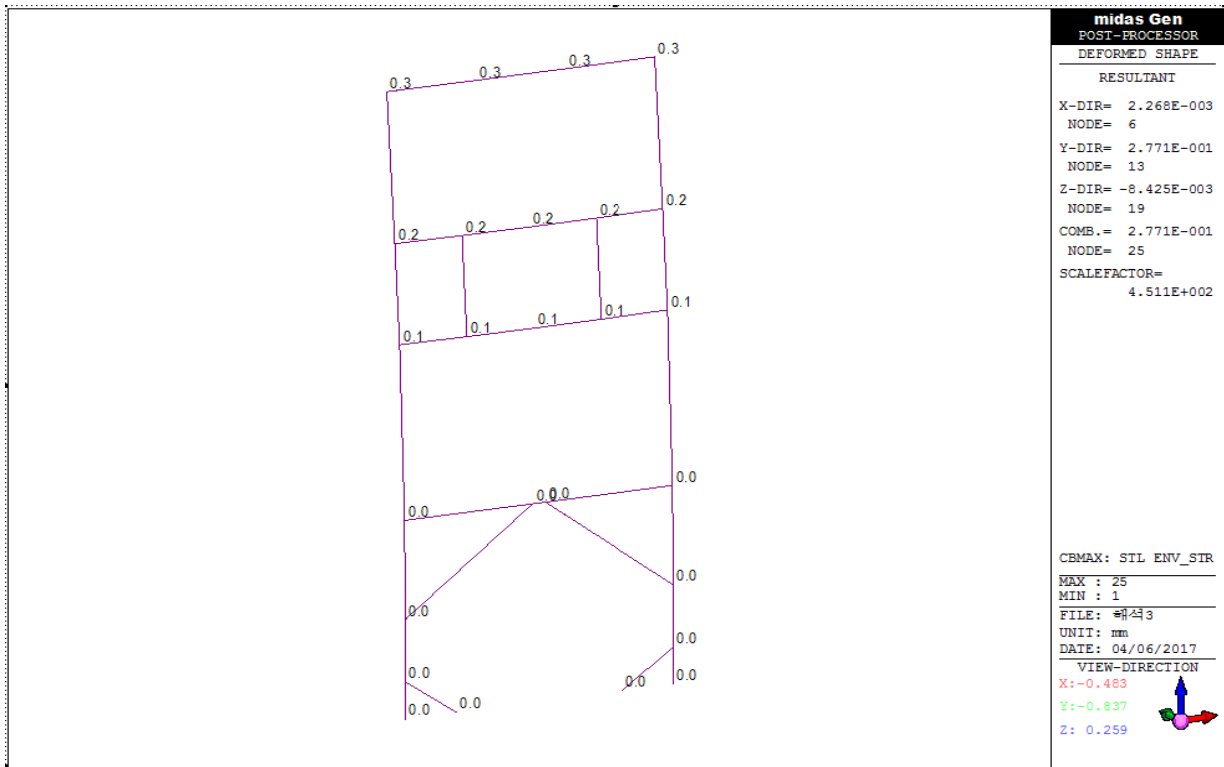

<Deformed Shape Diagram>

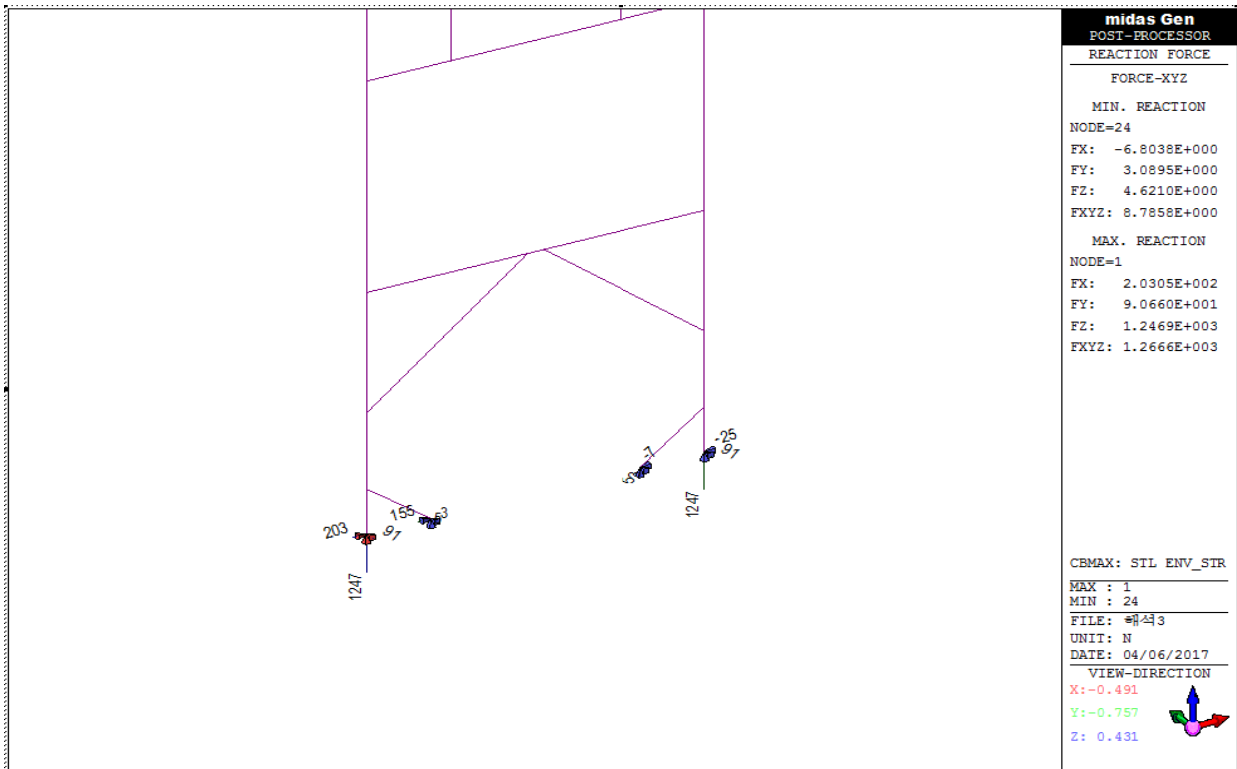

<Reaction Force Diagram - Vertical Force and Horizontal Force>

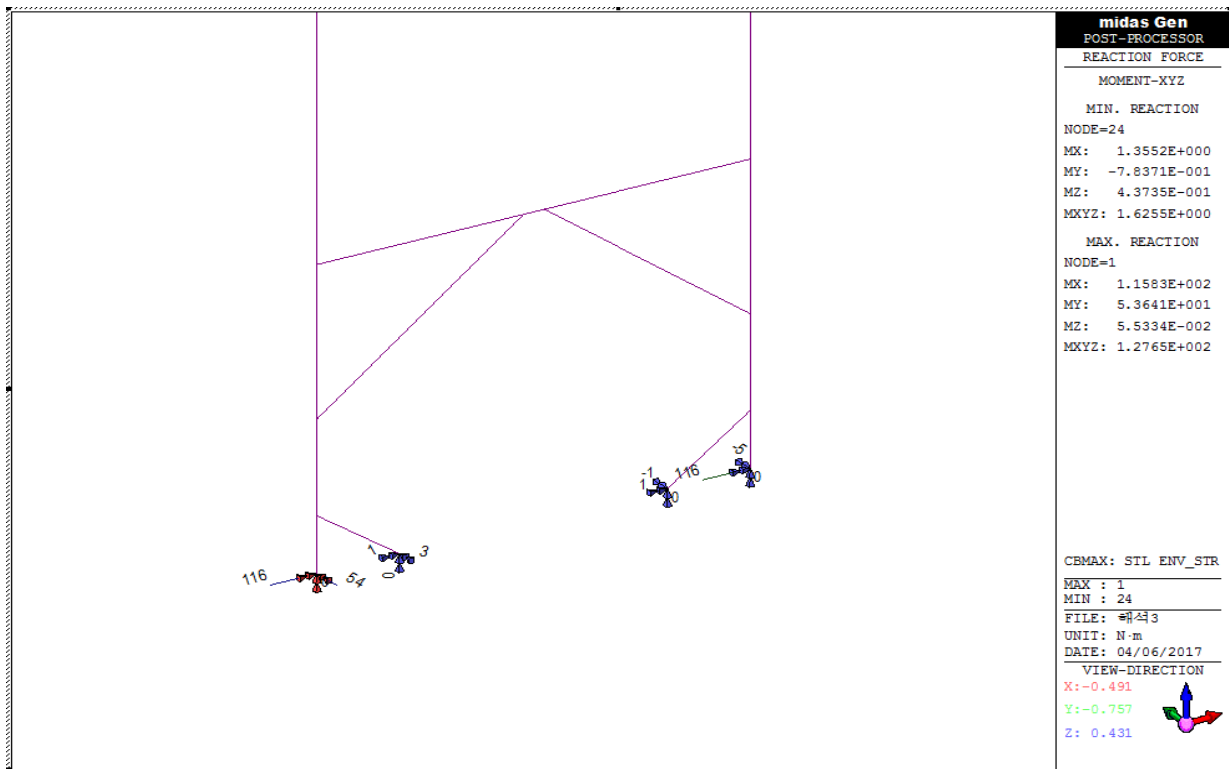

<Reaction Force Diagram - Bending Moment Diagram>

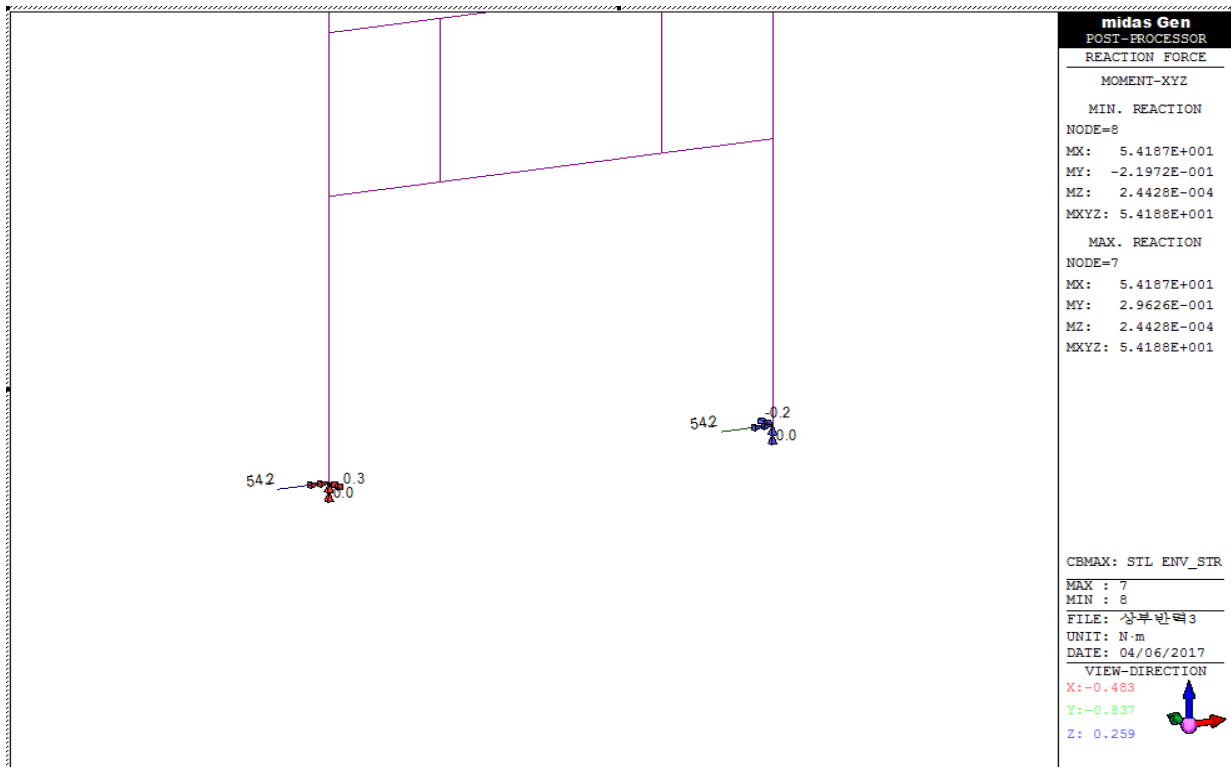

<Reaction Force Diagram of Upper Structure - Bending Moment Diagram>

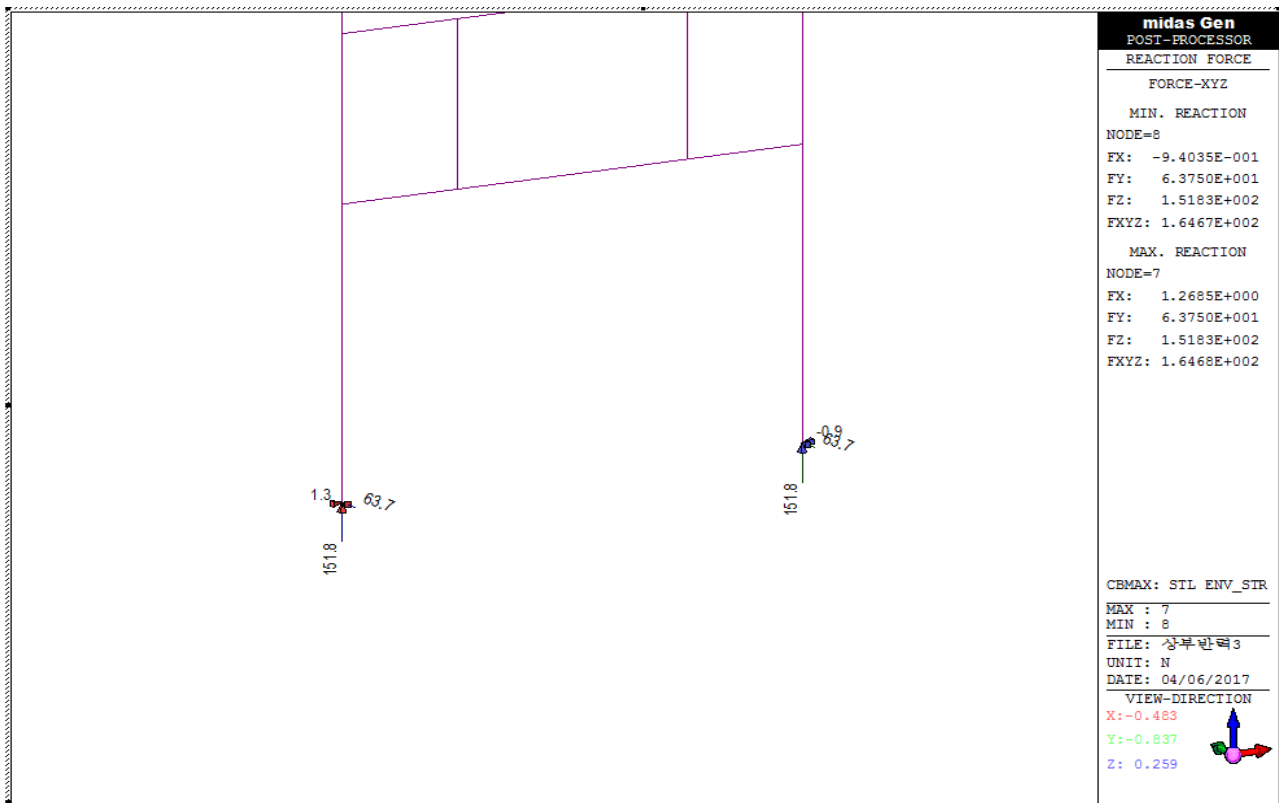

<Reaction Force Diagram of Upper Structure
 - Vertical Force and Horizontal Force>

1) Member Review

midas Gen

Steel Checking Result

Certified by :

	Company		Project Title	
	Author	SSY	File Name	E:\...해석3.mgb

1. Design Information

Design Code : KSSC-ASD03
 Unit System : kN, m
 Member No : 1
 Material : SS400 (No:1)
 (Fy = 235000, Es = 205000000)
 Section Name : CB (No:1)
 (Built-up Section).
 Member Length : 0.80000

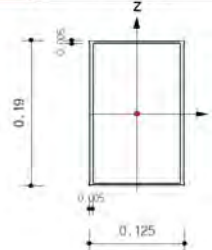

2. Member Forces

Axial Force Fxx = -0.9352 (LCB: 3, POS: 1)
 Bending Moments My = -0.1158, Mz = -0.0402
 End Moments Myi = -0.1158, Myj = -0.1027 (for Lb)
 Myi = -0.1158, Myj = -0.0542 (for Ly)
 Mzi = -0.0402, Mzj = -0.0174 (for Lz)
 Shear Forces Fyy = -0.3583 (LCB: 1, POS: 1/4)
 Fzz = -0.0907 (LCB: 3, POS: 1)

Depth	0.19000	Web Thick	0.00500
Flg Width	0.12500	Top F Thick	0.00500
Web Center	0.12000	Bot.F Thick	0.00500
Area	0.00305	Asz	0.00190
Qyb	0.00983	Qzb	0.00735
Iyy	0.00002	Izz	0.00001
Ybar	0.06250	Zbar	0.09500
Syy	0.00016	Szz	0.00013
ry	0.07142	rz	0.05157

3. Design Parameters

Unbraced Lengths Ly = 0.80000, Lz = 0.15000, Lb = 0.15000
 Effective Length Factors Ky = 1.00, kz = 1.00
 Moment Factor / Bending Coefficient Cmy = 0.85, Cmz = 0.85, Cb = 1.00

4. Checking Results

Slenderness Ratio
 $KL/r = 11.2 < 200.0$ (Memb:1, LCB: 3) 0.K
 Axial Stress
 $f_a/F_a = 307/137845 = 0.002 < 1.000$ 0.K
 Bending Stresses
 $f_{by}/F_{by} = 707/155100 = 0.005 < 1.000$ 0.K
 $f_{bz}/F_{bz} = 310/141000 = 0.002 < 1.000$ 0.K
 Combined Stress (Compression+Bending)
 $R_{max} = f_a/F_a + f_{bcy}/F_{bcy} + f_{bcz}/F_{bcz} = 0.009 < 1.000$ 0.K
 Shear Stresses
 $f_{vy}/F_{vy} = 0.003 < 1.000$ 0.K
 $f_{vz}/F_{vz} = 0.001 < 1.000$ 0.K

Certified by :

	Company		Project Title	
	Author	SSY	File Name	E:\...\해석3.mgb

1. Design Information

Design Code : KSSC-ASD03
 Unit System : kN, m
 Member No : 7
 Material : SS400 (No:1)
 (Fy = 235000, Es = 205000000)
 Section Name : CT (No:2)
 (Built-up Section).
 Member Length : 1.70000

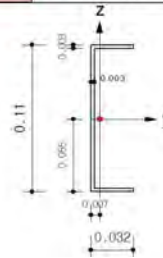

2. Member Forces

Axial Force Fxx = -0.1139 (LCB: 3, POS:1)
 Bending Moments My = -0.0542, Mz = -0.0006
 End Moments Myi = -0.0542, Myj = -0.0187 (for Lb)
 Myi = -0.0542, Myj = 0.00000 (for Ly)
 Mzi = -0.0006, Mzj = 0.00057 (for Lz)
 Shear Forces Fyy = -0.0057 (LCB: 1, POS:1/2)
 Fzz = -0.0637 (LCB: 3, POS:1)

Depth	0.11000	Web Thick	0.00300
Top F Width	0.03200	Top F Thick	0.00300
Bot.F Width	0.03200	Bot.F Thick	0.00300
Area	0.00050	Asz	0.00033
Oyb	0.00306	Ozb	0.00031
Iyy	0.00000	Izz	0.00000
Ybar	0.00702	Zbar	0.05500
Syy	0.00002	Szz	0.00000
ry	0.04060	rz	0.00909

3. Design Parameters

Unbraced Lengths Ly = 1.70000, Lz = 0.70000, Lb = 0.70000
 Effective Length Factors Ky = 1.00, Kz = 1.00
 Moment Factor / Bending Coefficient
 Cmy = 0.85, Cmz = 0.85, Cb = 1.00

4. Checking Results

Slenderness Ratio
 $KL/r = 77.0 < 200.0$ (Memb:7, LCB: 3) 0.K
 Axial Stress
 $fa/Fa = 226 / 104483 = 0.002 < 1.000$ 0.K
 Bending Stresses
 $fby/Fby = 3587 / 103481 = 0.035 < 1.000$ 0.K
 $fbz/Fbz = 336 / 141000 = 0.002 < 1.000$ 0.K
 Combined Stress (Compression+Bending)
 $Rmax = fa/Fa + fbcy/Fbcy + fbcz/Fbcz = 0.037 < 1.000$ 0.K
 Shear Stresses
 $fv_y/Fv_y = 0.000 < 1.000$ 0.K
 $fv_z/Fv_z = 0.002 < 1.000$ 0.K

Certified by :

	Company		Project Title	
	Author	SSY	File Name	E:\... \해설 석3.mgb

1. Design Information

Design Code : KSSC-ASD03
 Unit System : kN, m
 Member No : 15
 Material : SS400 (No:1)
 (Fy = 235000, Es = 205000000)
 Section Name : BM (No:3)
 (Built-up Section).
 Member Length : 1.05000

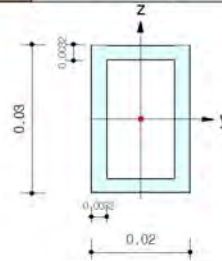

2. Member Forces

Axial Force $F_{xx} = -0.0024$ (LCB: 1, POS:J)
 Bending Moments $M_y = -0.0020$, $M_z = 0.00000$
 End Moments $M_{yi} = -0.0020$, $M_{yj} = -0.0020$ (for Lb)
 $M_{yi} = 0.00136$, $M_{yj} = -0.0020$ (for Ly)
 $M_{zi} = 0.00000$, $M_{zj} = 0.00000$ (for Lz)
 Shear Forces $F_{yy} = 0.00007$ (LCB: 3, POS:I)
 $F_{zz} = 0.01556$ (LCB: 1, POS:J)

Depth	0.03000	Web Thick	0.00320
Flg Width	0.02000	Top F Thick	0.00320
Web Center	0.01680	Bot F Thick	0.00320
Area	0.00028	Asz	0.00019
Qyb	0.00020	Qzb	0.00015
Iyy	0.00000	Izz	0.00000
Ybar	0.01000	Zbar	0.01500
Syy	0.00000	Szz	0.00000
ry	0.01039	rz	0.00734

3. Design Parameters

Unbraced Lengths $L_y = 0.26250$, $L_z = 1.05000$, $L_b = 1.05000$
 Effective Length Factors $K_y = 1.00$, $K_z = 1.00$
 Moment Factor / Bending Coefficient $C_{my} = 1.00$, $C_{mz} = 1.00$, $C_b = 1.00$

4. Checking Results

Slenderness Ratio
 $KL/r = 143.0 < 200.0$ (Memb:15, LCB: 1)..... 0.K
 Axial Stress
 $f_a/F_a = 8.7/51651.5 = 0.000 < 1.000$ 0.K
 Bending Stresses
 $f_{by}/F_{by} = 987/ 141000 = 0.007 < 1.000$ 0.K
 $f_{bz}/F_{bz} = 0/ 141000 = 0.000 < 1.000$ 0.K
 Combined Stress (Compression+Bending)
 $R_{max} = f_a/F_a + f_{bcy}/F_{bcy} + f_{bcz}/F_{bcz} = 0.007 < 1.000$ 0.K
 Shear Stresses
 $f_{vy}/F_{vy} = 0.000 < 1.000$ 0.K
 $f_{vz}/F_{vz} = 0.001 < 1.000$ 0.K

Certified by :

	Company		Project Title	
	Author	SSY	File Name	E:\...\해석3.mgb

1. Design Information

Design Code : KSSC-ASD03
 Unit System : kN, m
 Member No : 13
 Material : SS400 (No:1)
 (Fy = 235000, Es = 205000000)
 Section Name : BB (No:4)
 (Built-up Section).
 Member Length : 1.05000

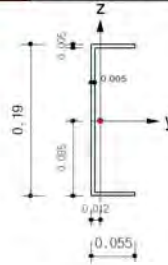

2. Member Forces

Axial Force Fxx = 0.04013 (LCB: 1, POS:J)
 Bending Moments My = 0.00000, Mz = 0.03663
 End Moments Myi = 0.00000, Myj = 0.00000 (for Lb)
 Myi = 0.00000, Myj = 0.00000 (for Ly)
 Mzi = 0.02252, Mzj = 0.03663 (for Lz)
 Shear Forces Fyy = -0.4066 (LCB: 1, POS:J)
 Fzz = 0.00228 (LCB: 3, POS:1/4)

Depth	0.19000	Web Thick	0.00500
Top F Width	0.05500	Top F Thick	0.00500
Bot.F Width	0.05500	Bot.F Thick	0.00500
Area	0.00145	Asz	0.00095
Oyb	0.00914	Ozb	0.00093
Iyy	0.00001	Izz	0.00000
Ybar	0.01198	Zbar	0.09500
Syy	0.00008	Szz	0.00001
ry	0.07016	rz	0.01562

3. Design Parameters

Unbraced Lengths Ly = 1.05000, Lz = 0.50000, Lb = 0.50000
 Effective Length Factors Ky = 1.00, Kz = 1.00
 Moment Factor / Bending Coefficient Cmy = 1.00, Cmz = 1.00, Cb = 1.00

4. Checking Results

Slenderness Ratio L/r = 32.0 < 300.0 (Mem:13, LCB: 1)..... 0.K
 Axial Stress ft/Ft = 28/ 141000 = 0.000 < 1.000 0.K
 Bending Stresses fby/Fby = 0/ 155100 = 0.000 < 1.000 0.K
 fbz/Fbz = 4452/ 141000 = 0.032 < 1.000 0.K
 Combined Stress (Tension+Bending) Rmax = fbcy/Fbcy + fbcz/Fbcz = 0.032 < 1.000 0.K
 Shear Stresses fvy/Fvy = 0.012 < 1.000 0.K
 fvz/Fvz = 0.000 < 1.000 0.K

Certified by :

MIDAS	Company		Project Title	
	Author	SSY	File Name	E:\...\해석\3.mgb

1. Design Information

Design Code : KSSC-ASD03
 Unit System : kN, m
 Member No : 14
 Material : SS400 (No:1)
 (Fy = 235000, Es = 205000000)
 Section Name : BT (No:5)
 (Built-up Section).
 Member Length : 1.05000

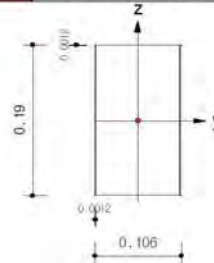

2. Member Forces

Axial Force $F_{xx} = -0.0033$ (LCB: 1, POS:1/2)
 Bending Moments $M_y = 0.00000, M_z = 0.01330$
 End Moments $M_{yi} = 0.00000, M_{yj} = 0.00000$ (for Lb)
 $M_{yi} = 0.00000, M_{yj} = 0.00000$ (for Ly)
 $M_{zi} = -0.0011, M_{zj} = -0.0011$ (for Lz)
 Shear Forces $F_{yy} = 0.05473$ (LCB: 1, POS:J)
 $F_{zz} = 0.00000$ (LCB: 3, POS:1/2)

Depth	0.19000	Web Thick	0.00120
Flg Width	0.10600	Top F Thick	0.00120
Web Center	0.10480	Bot, F Thick	0.00120
Area	0.00070	Asz	0.00046
Oyb	0.00940	Ozb	0.00632
Iyy	0.00000	Izz	0.00000
Ybar	0.05300	Zbar	0.09500
Syy	0.00004	Szz	0.00003
ry	0.07135	rz	0.04574

3. Design Parameters

Unbraced Lengths $L_y = 1.05000, L_z = 1.05000, L_b = 1.05000$
 Effective Length Factors $K_y = 1.00, K_z = 1.00$
 Moment Factor / Bending Coefficient $C_{my} = 1.00, C_{mz} = 1.00, C_b = 1.00$

4. Checking Results

Slenderness Ratio $KL/r = 23.0 < 200.0$ (Mem:14, LCB: 1)..... 0.K
 Axial Stress $f_a/F_a = 4.6/48231.0 = 0.000 < 1.000$ 0.K
 Bending Stresses $f_{by}/F_{by} = 0/155100 = 0.000 < 1.000$ 0.K
 $f_{bz}/F_{bz} = 1257/141000 = 0.009 < 1.000$ 0.K
 Combined Stress (Compression+Bending) $R_{max} = f_a/F_a + f_{bcy}/F_{bcy} + f_{bcz}/F_{bcz} = 0.009 < 1.000$ 0.K
 Shear Stresses $f_{vy}/F_{vy} = 0.002 < 1.000$ 0.K
 $f_{vz}/F_{vz} = 0.000 < 1.000$ 0.K

Certified by :

	Company		Project Title	
	Author	SSY	File Name	E:\...\해석3.mgb

1. Design Information

Design Code : KSSC-ASD03
 Unit System : kN, m
 Member No : 28
 Material : SS400 (No:1)
 (Fy = 235000, Es = 205000000)
 Section Name : BD (No:6)
 (Built-up Section).
 Member Length : 0.64031

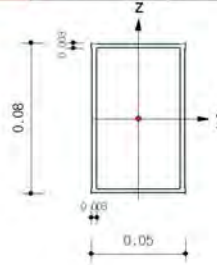

2. Member Forces

Axial Force $F_{xx} = -0.5528$ (LCB: 1, POS: 1)
 Bending Moments $M_y = -0.0145$, $M_z = 0.00000$
 End Moments $M_{yi} = -0.0145$, $M_{yj} = 0.01269$ (for Lb)
 $M_{yi} = -0.0145$, $M_{yj} = 0.01269$ (for Ly)
 $M_{zi} = 0.00000$, $M_{zj} = 0.00000$ (for Lz)
 Shear Forces $F_{yy} = 0.00228$ (LCB: 3, POS: 1/2)
 $F_{zz} = -0.0568$ (LCB: 1, POS: 1)

Depth	0.08000	Web Thick	0.00300
Flg Width	0.05000	Top F Thick	0.00300
Web Center	0.04700	Bot.F Thick	0.00300
Area	0.00074	Asz	0.00048
Qyb	0.00185	Qzb	0.00118
Iyy	0.00000	Izz	0.00000
Ybar	0.02500	Zbar	0.04000
Syy	0.00002	Szz	0.00001
ry	0.02950	rz	0.02035

3. Design Parameters

Unbraced Lengths $L_y = 0.64031$, $L_z = 0.64031$, $L_b = 0.64031$
 Effective Length Factors $K_y = 1.00$, $K_z = 1.00$
 Moment Factor / Bending Coefficient $C_{my} = 1.00$, $C_{mz} = 1.00$, $C_b = 1.00$

4. Checking Results

Slenderness Ratio
 $KL/r = 31.5 < 200.0$ (Memb:28, LCB: 1)..... 0.K
 Axial Stress
 $f_a/F_a = 743/ 130062 = 0.006 < 1.000$ 0.K
 Bending Stresses
 $f_{by}/F_{by} = 895/ 155100 = 0.006 < 1.000$ 0.K
 $f_{bz}/F_{bz} = 0/ 141000 = 0.000 < 1.000$ 0.K
 Combined Stress (Compression+Bending)
 $R_{max} = f_a/F_a + f_{bcy}/F_{bcy} + f_{bcz}/F_{bcz} = 0.011 < 1.000$ 0.K
 Shear Stresses
 $f_{vy}/F_{vy} = 0.000 < 1.000$ 0.K
 $f_{vz}/F_{vz} = 0.001 < 1.000$ 0.K

2) Connecting Bolt of Upper-Lower Member (Base+Monitor)

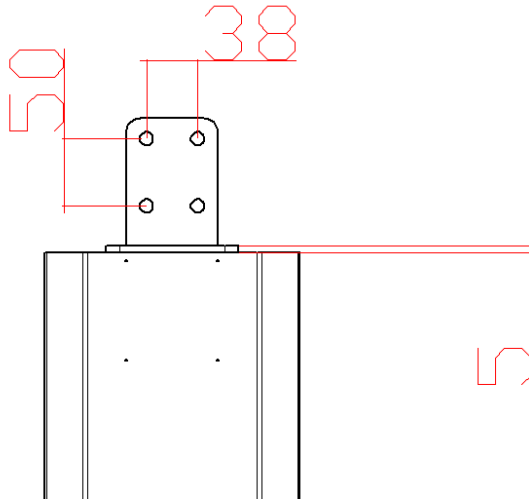

① Internal Force of Wrench Bolt M10

$$F_y = 325\text{MPa}, \quad F_a = 117\text{MPa}, \quad A = 78.5\text{mm}^2$$

$$V_r = 9.18\text{kN/ea}$$

② Design Load

$$M = 54.2 \text{ N.m}$$

$$V_x = 64\text{N}, \quad R_x = V_x/4 = 16.0\text{N/ea}$$

$$V_y = 152\text{N}, \quad R_y = V_y/4 = 38.0\text{N/ea}$$

③ Bolt Review

$$\sum(x_i^2 + y_i^2) = 4(19^2 + 25^2) = 3944$$

$$R_{m,x} = \frac{M \times y_m}{\sum(x^2 + y^2)} = \frac{54.2 \times 1000 \times 25}{3944} = 344\text{N/ea}$$

$$R_{m,y} = \frac{M \times x_m}{\sum(x^2 + y^2)} = \frac{54.2 \times 1000 \times 19}{3944} = 261\text{N/ea}$$

$$R = \sqrt{(R_{m,x} + V_x)^2 + (R_{m,y} + V_y)^2} = \sqrt{(344 + 16.0)^2 + (261 + 38.0)^2} = 468\text{N/ea}$$

$$\langle V_r = 9.18\text{kN/ea} \quad \text{-----} \rangle \text{ O.K}$$

3) Connecting Bolt of Foundation Member

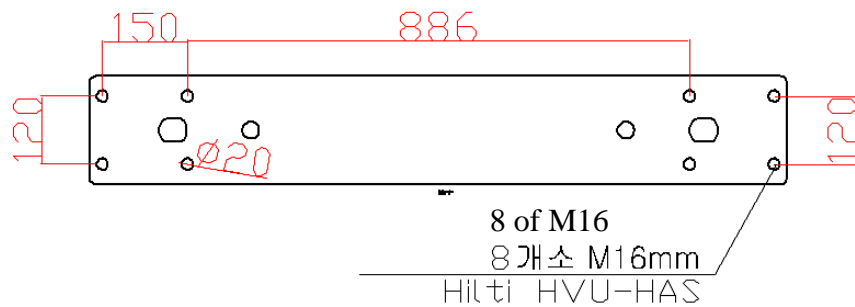

① Internal Force of Hilti HVU-HAS M16 (Refer to Hilti Manual)

$$F_{z,r} = 24.8\text{kN}$$

$$F_{x,r} = 24.7\text{kN}$$

② Design Load

$$M = 116 \text{ N.m}$$

$$F_z = 1247\text{N}$$

$$V_x = 203\text{N}$$

$$V_y = 92\text{N}$$

③ Axial Force Review

$$M/d + F_z = 116/0.12 + 1247 = 967 + 1247 = 2214\text{N} < F_{z,r} = 24.8\text{kN} \quad \text{-----} > \text{O.K}$$

④ Shear Force Review

$$V = (V_x^2 + V_y^2)^{0.5} = 223\text{N} < F_{x,r} = 24.7\text{kN} \quad \text{-----} > \text{O.K}$$

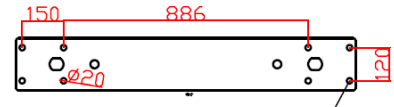
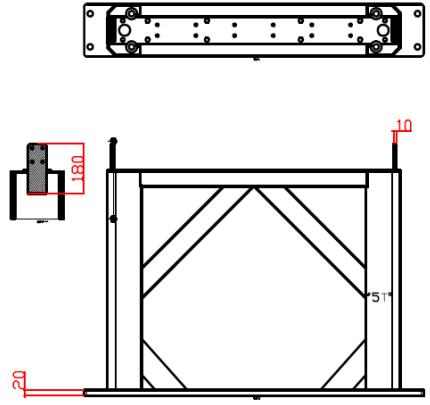
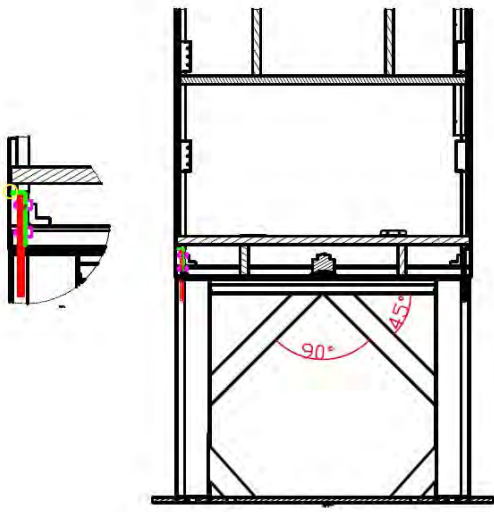

8개소 M20mm안카 볼트
8 of M20 Anchor bolt

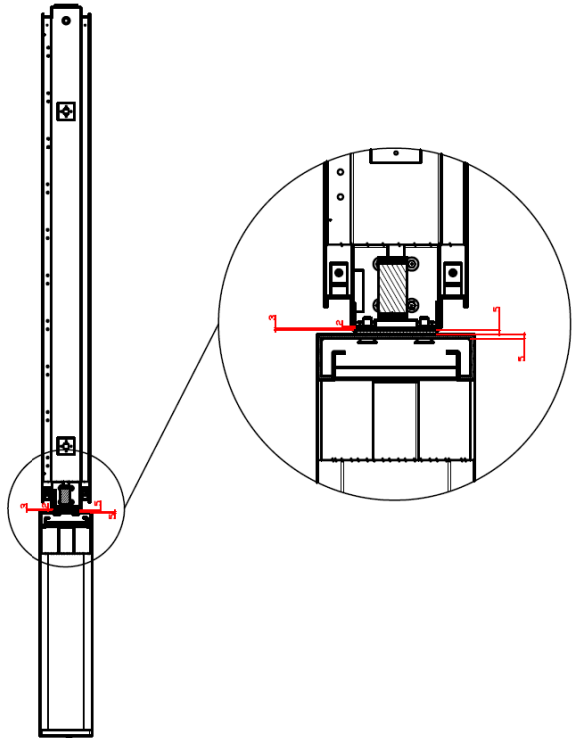
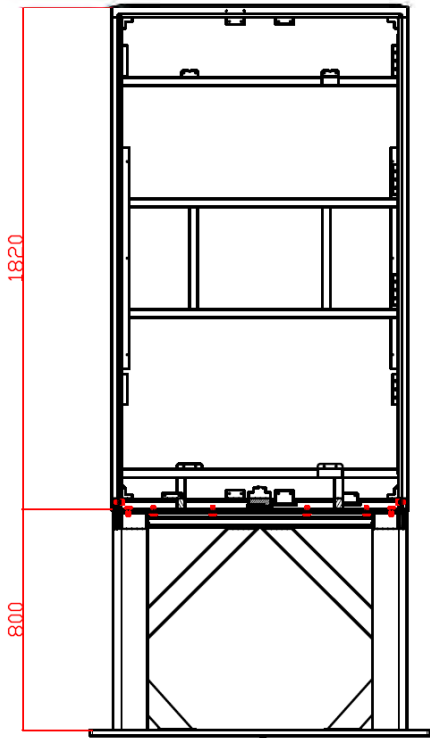

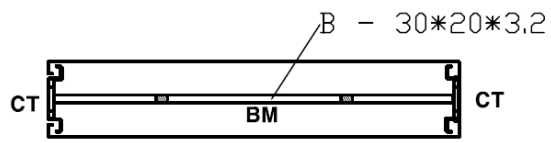

Section view B-B



Section view C-C

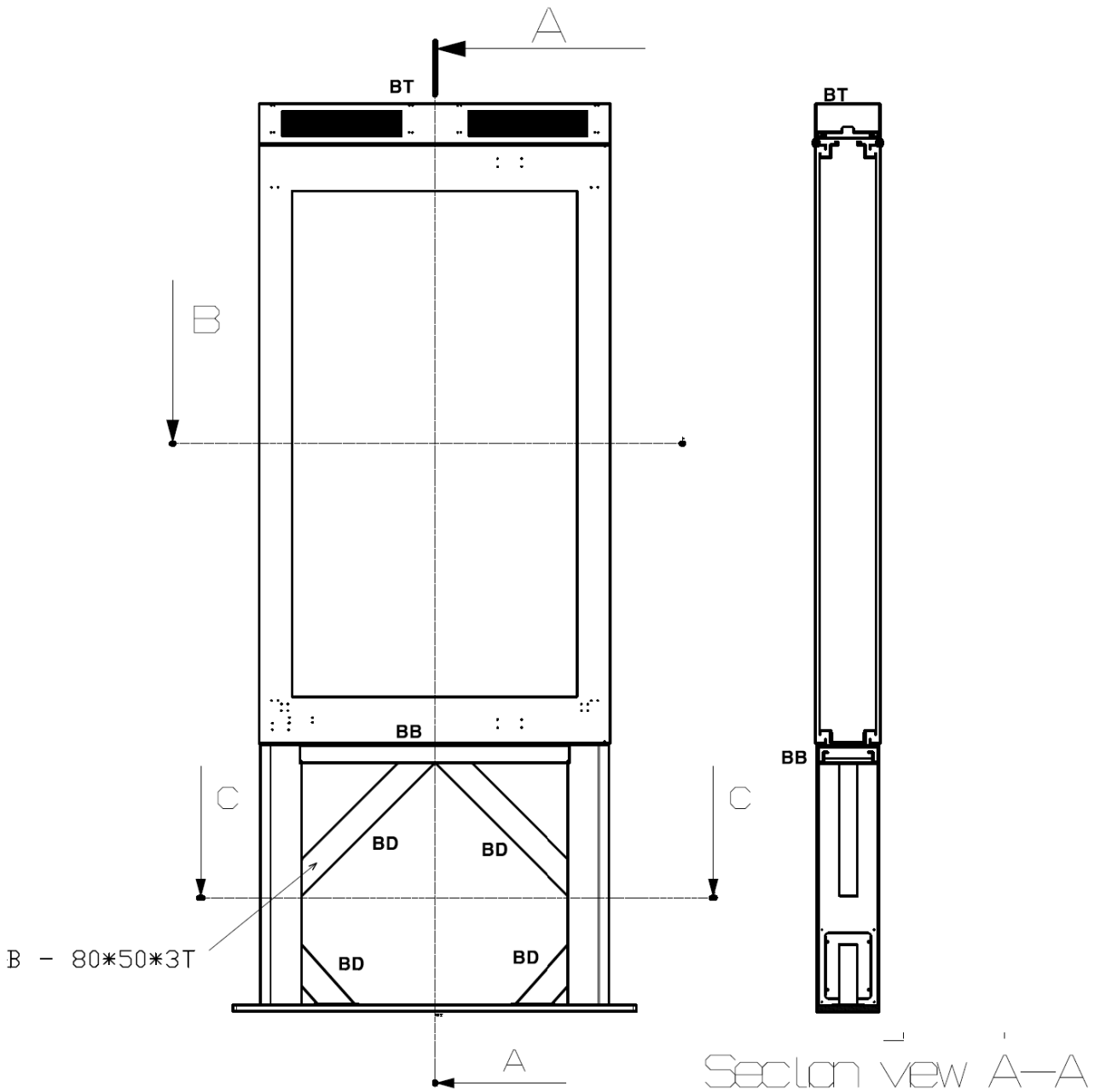

Section view A-A

Approximative Member Section

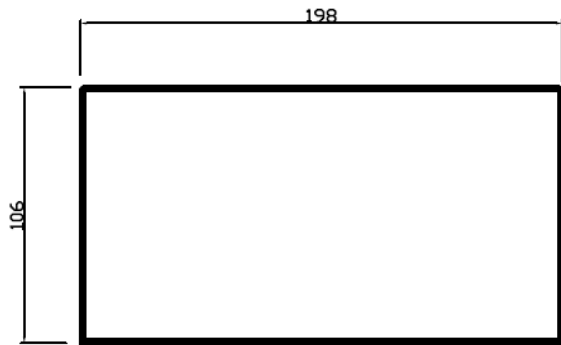

BT

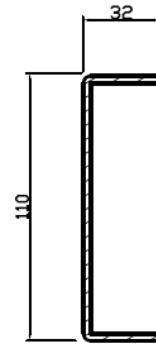

CT

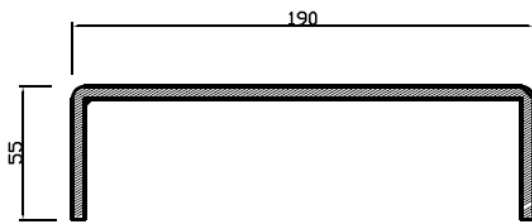

BB

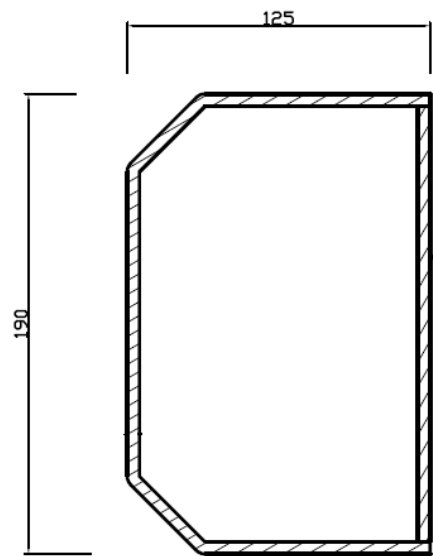

CB

The 5th Chapter. Review Result

1) The 70inch advertising board installed in Oslo subway station secured structural safety on dead load and 100 Pa of wind load in subway station and leaning load, if it is installed as reviewed drawing.

This is to confirm that model #NIOD-700P, 70" Double-sided transit KIOSK, is structurally safe on dead load and 100 Pa of wind load in subway station at Oslo subway station as reviewed drawing.



2 Österås

31112

32115

Clear Channel



Morgon utgångsavgift breddad till eftermiddag

8 AR PÅ RAD!

altibox

— Läs och tillräckligt





Clear Channel



HØR,

Spesialt uten mobilnett 10 min. gratis, 40 langtidsopringninger.
Utenfor Oslo: Spesialt uten mobilnett 10 min. gratis, 40 langtidsopringninger.

Clear Channel



HØR, . . .

Spesialt uten mobilnett 10 min. gratis, 40 langtidsopringninger.
Utenfor Oslo: Spesialt uten mobilnett 10 min. gratis, 40 langtidsopringninger.

Hold avstand til
plattformen
Stay clear of platform edge

Fare!
Strömmande skåne
Caution
Third rail

Clear Channel



HØR, . . .

Spesialt uten mobilnett 10 min. gratis, 40 langtidsopringninger.
Utenfor Oslo: Spesialt uten mobilnett 10 min. gratis, 40 langtidsopringninger.

Clear Channel



HØR,

Spesialt uten mobilnett 10 min. gratis, 40 langtidsopringninger.
Utenfor Oslo: Spesialt uten mobilnett 10 min. gratis, 40 langtidsopringninger.